

Sandvik Rock Processing Australia Pty Limited (SRPAU)

Stationary screens and feeders manufacturing specifications

# **Vibrating machine safety manual**

**Information Security Class: Restricted (i2)**

**Document number: ENG-SDS-99**

**Version No.: V4.0 - MAJOR**

**Release Date: 25/03/2024**

## Condition of Use

Prior to use, **especially when using a printed version**, ensure that this document is the most recent version by checking the published version on the Sandvik Rock Processing Australia Pty Limited (SRPAU) Intranet. The version published on the SRPAU Intranet is always considered the official and most current version of this document.

The information in this publication is subject to change without notice. *Every effort was made to ensure the accuracy of the information contained herein. However, SRPAU makes no warranty as to the correctness of this information.*

All third-party products mentioned are trademarks of their respective producers.

## Copyright © Sandvik Rock Processing Australia Pty Limited 2024 All rights reserved.

This document is made available as a confidential disclosure, and any unauthorised use, alteration, disclosure, distribution in any form or by any means (including any attachments) or reproduction of this manual, even by excerpt, regardless of method, without prior permission in writing by (SRPAU) ABN 91 073 312 437 is strictly prohibited.

For permission contact:

Regional President APAC,  
Sandvik Rock Processing Australia Pty Limited,  
PO Box 153, North Ryde BC, NSW1671, Australia.

OR

Ground floor, 65 Epping Road,  
North Ryde, NSW 2113, Australia.

Tel: +61 2 9886 6800

Fax: +61 2 9878 4400

Email: [srp.au@sandvik.com](mailto:srp.au@sandvik.com)

Website: [Rock Processing \(https://www.rockprocessing.sandvik\)](https://www.rockprocessing.sandvik)

### Document Control Information

Document title: **Vibrating machine safety manual**

Document number:	Version number:	Release date:	Create date:	Next review date:
ENG-SDS-99	V4.0	25/03/2024	14/12/2021	14/03/2027
Author(s): Frank Chand Technical Document Writer		Reviewer(s): D Teyhan Principal Engineer- Vibrating		Approver: D Teyhan Principal Engineer- Vibrating

Filename: [https://sandvik.sharepoint.com/teams/p1ausportal/ims/eng/ENG-SDS-99\\_Vibrating Equipment Safety Manual.docx](https://sandvik.sharepoint.com/teams/p1ausportal/ims/eng/ENG-SDS-99_Vibrating Equipment Safety Manual.docx)

See the Version History of this document on the relevant SharePoint library where this document is stored to view a chronicle of the change made to this document.

Comments are welcome and if incorporated in this document, then that information becomes the property of Sandvik Rock Processing Australia Pty Limited.

**Note:** To request a change to this document, please contact the author or approver of this document.

**Uncontrolled copy when printed and/or not accessed from official Sandvik Rock Processing Australia Pty Ltd Intranet site.**

## Document control process

This controlled document is created under the 'QMS baseline documents' created for implementing ISO 9001:2008 at SRPAU. It defines the controls needed to approve, review, update, identify changes, identify revision status, and provide access to controlled documents. It defines the scope, purpose, method, and responsibilities required to implement these parameters.

## Document Revision History

Rev	Date	Description	By	Approved
1	10/12/2021	Approved for use	F Chand	J Kirsch
2	29/03/2022	Revised as SPG Legal Comments. Oil sampling information added – Section 8.5.1 Table 2	F Chand	J Kirsch
3	04/05/2023	Documents republished. No change from Rev. 2.0	F Chand	F Chand
4	25/03/2024	Feeder, grizzly and vibrator motor safety information added	F Chand	D Teyhan

# Contents

1	Introduction .....	6
1.1	Occupational health and safety .....	6
1.2	Safety notes .....	6
1.3	Contact us .....	8
2	Screen components .....	9
2.1	Vibrating machine major components .....	9
2.2	Major screen components .....	10
2.3	Major exciter driven feeder components .....	11
2.4	Major suspended feeder components .....	12
2.5	Major grizzly feeder components .....	13
3	Signal words for safety warnings .....	14
3.1	Signal word severity .....	14
3.2	Signal Words for Application Notes .....	14
3.3	General electrical safety requirements .....	14
3.4	Damaged / Defective electrical components .....	15
3.5	System hazards .....	15
3.6	Moving equipment hazard .....	17
3.7	Operational hazards .....	18
3.8	Stored mechanical energy hazards .....	18
4	General safety .....	19
4.1	Safety for installation, operation, and maintenance activities .....	19
5	Installation and commissioning safety .....	21
5.1	Installation, commissioning safety procedures .....	21
5.2	Transport beams safety .....	23
5.3	Exciter and drive train guarding .....	24
5.4	Isolation frame and vibrating machine installation precautions .....	25
6	Operational safety .....	27
6.1	Operational safety precautions .....	27
6.2	Vibrating machine and exciter start-up procedures .....	28
7	Operator connected and control system created hazards .....	30
7.1	Prestart checks .....	30
7.2	Pre-stop checks .....	30
7.3	Checks prior to starting feed onto the vibrating machine .....	30
7.4	Checks after commencement of feed onto the vibrating machine and periodic checks .....	31
8	Maintenance safety .....	32
8.1	Maintenance safety procedures .....	32
8.2	Spring removal and replacement safety procedures .....	34
8.3	Screen deck panel maintenance .....	36
8.4	Feeder pan liner maintenance .....	36
8.5	Grizzly bar, Impact pan, Side Liner and Deflector maintenance .....	37
8.6	Exciter and drivetrain maintenance .....	38
8.7	Exciter, drive train and vibrator motor safety critical inspections .....	42
8.8	Lubrication safety .....	44
9	Decommissioning, dismantling, transport, recycle and disposal .....	45
9.1	Decommissioning .....	45
9.2	Dismantling .....	45
9.3	Transport .....	45
9.4	Recycling .....	46
9.5	Disposal .....	46

**Uncontrolled copy when printed and/or not accessed from official Sandvik Rock Processing Australia Pty Ltd Intranet site.**

Title: Vibrating machine safety manual, Document Num: ENG-SDS-99

Approved By: D Teyhan, Approved Version: V4.0, Approval Date: 25/03/2024,

Filename: [https://sandvik.sharepoint.com/teams/p1ausportal/ims/eng/ENG-SDS-99\\_Vibrating Equipment Safety Manual.docx](https://sandvik.sharepoint.com/teams/p1ausportal/ims/eng/ENG-SDS-99_Vibrating Equipment Safety Manual.docx)

## Figures

Figure 2.2-1 Main features of a double deck multi slope screen.....	10
Figure 2.3-1 Main features of an exciter driven feeder .....	11
Figure 2.4-1 Main features of a suspended feeder .....	12
Figure 2.5-1: Main features of a grizzly .....	13
Figure 3.8-1- Exciter swing segment in “Rest position” .....	18
Figure 5.2-1: Example of rated supports for transport beam installation and removal.....	23
Figure 5.3-1: Exciter and drive train guarding.....	24
Figure 8.6-1: Exciter swing segment in “Rest position” .....	39
Figure 8.6-2: Swing segments secured with transport clamps.....	39
Figure 8.6-3 Generic exciter drive shaft and coupling assembly .....	41
Figure 8.6-4 Example exciter & drive train assembly.....	41

## Tables

Table 8.7-1 On-line Check List .....	42
Table 8.7-2: Off-Line Check List.....	43

# 1 Introduction

## 1.1 Occupational health and safety

- 1.1.1 Always follow all procedures relevant to the work being carried out as detailed in the Sandvik manuals supplied with the equipment.
- 1.1.2 This manual does not contain specific information regarding national or state laws and regulations regarding your company and personal legal obligation to occupational, health and safety laws and/or requirements for environmental protection. Specific information and compliance can include but not be limited to:
- Risk assessment of machine installation, machine, associated equipment, machine operation and maintenance, modifications to existing plant or implementing “control measures” where applicable.
  - Training and registration of maintenance personnel to maintain the equipment in a fit and proper state to perform the task as designed.
  - The collation and storage of all plant maintenance and modification records.
  - Isolation of system energy including surrounding equipment during plant maintenance and inspection.
  - “Lock-out” and / or “tag out” of system energy to prevent entanglement, engulfment, or accident.
  - Training and registration of operational personnel.
  - Permit system to “enter confined spaces”.
  - Permit system for the “Authority to work”.
  - Development of process and equipment specific Standard Operating Procedures (referred to herein after as SOP).
  - Appropriate lighting for installation, operation, and maintenance of the vibrating machine.
- 1.1.3 Sandvik recommends that your company seeks the advice of the relevant state authority regarding the applicable information and requirements, company Occupational Health & Safety (hereinafter also referred as OH&S) manager, or an independent OH&S consultant.
- 1.1.4 Plant designers and operators must have precautions in place to mitigate, manage and limit occupational exposure where the vibrating machine is in operation.
- 1.1.5 Dependent on the site and plant conditions, access and egress points and paths, and work being conducted on the screen, etc. the space between decks on double deck screens may be considered as an area with restricted means for entry and exit. This classification may vary between jurisdictions, and it is therefore up to the owner / operator to assess and implement appropriate controls during maintenance. We cannot provide more specific guidance due to the varying nature of influencing factors.

## 1.2 Safety notes

- 1.2.1 Follow the safety regulations listed below to avoid personal injury and material damage.
- 1.2.2 Also pay attention to:
- Safety instructions given in order-specific documentation.
  - Safety instructions relating to mechanical components.
  - Instructions and safety tips for parts manufactured by sub-suppliers or that are not part of Sandvik scope of delivery.

***Uncontrolled copy when printed and/or not accessed from official Sandvik Rock Processing Australia Pty Ltd Intranet site.***

*Title: Vibrating machine safety manual, Document Num: ENG-SDS-99*

*Approved By: D Teyhan, Approved Version: V4.0, Approval Date: 25/03/2024,*

*Filename: [https://sandvik.sharepoint.com/teams/p1ausportal/ims/eng/ENG-SDS-99\\_Vibrating Equipment Safety Manual.docx](https://sandvik.sharepoint.com/teams/p1ausportal/ims/eng/ENG-SDS-99_Vibrating Equipment Safety Manual.docx)*

1.2.3 Observe all applicable codes of practice when performing installation, commissioning, and service work.

1.2.3.1 Intended application

The Vibrating Screening system and its connected mechanical components are exclusively designed for screening tasks as outlined in the installation, operation and maintenance (IOM) manual (hereinafter also referred as the IOM manual) provided with the machine. Similarly, Vibrating Feeder systems and their connected mechanical components are exclusively for feeding tasks as outlined in the IOM manual provided with the machine. Any use beyond this intent is considered not intended.

1.2.3.2 Sources of risk

If the system has been installed, commissioned as per Sandvik manual and/or as instructed in writing (e-mail is sufficient) by Sandvik and is in good working order, it should not pose any danger during vibrating equipment operations. Hazards may arise when the system is used incorrectly, especially when not used as per Sandvik manual.

The vibrating machine can be part of a more complex plant. The plant operating company is fully responsible for the operating safety of the plant.

1.2.3.3 Personnel

Preparation, assembly, commissioning, operation, maintenance, and servicing may only be carried out by qualified personnel.

The operating company is responsible for instructing its operators to observe all regulations and instructions given by Sandvik.

All persons working on the vibrating machine system are required to observe the safety advice given by Sandvik's manuals, this manual or any other further written (e-mail is sufficient) instructions provided by Sandvik and know the parts of the technical documentation relevant to their work.

1.2.3.4 Changing parameters

The vibrating machines' system functionality is determined and influenced by various parameters. Only personnel familiar with the devices' mode of operation may alter these parameters after written (e-mail is sufficient) approval of Sandvik.

Incorrectly set parameters may cause injury or material (equipment) damage. Furthermore, they may also cause considerable disruption to vibrating machine operations.

1.2.3.5 Password

Passwords safeguard the condition monitoring parameters against unauthorized alteration. The vibrating machine system operating company must ensure that the password is handled safely.

1.2.3.6 Acknowledging event messages

Condition monitoring warning messages may be acknowledged only after the cause of the fault has been remedied.

Ensure that any connected peripheral devices are functioning correctly before acknowledging an event. Any connected control systems in particular must be in a safe state.

1.2.3.7 Service and maintenance

- All warning and instruction signs on the vibrating machine and associated equipment must be observed.

***Uncontrolled copy when printed and/or not accessed from official Sandvik Rock Processing Australia Pty Ltd Intranet site.***

- The upstream equipment must be shut down before work is performed on mechanical equipment or peripheral devices (control systems in particular). Take appropriate action to ensure that the upstream equipment cannot be inadvertently restarted.
- Before performing work on the electrical equipment, disconnect and isolate from the power supply by qualified and competent authorised personnel.
- The electrical devices may only be operated in the enclosures provided, as there would otherwise be a risk of coming into contact with live parts.

#### 1.2.3.8 Moisture and humidity

All Condition monitoring parts, electrical components in particular, must be protected from moisture and humidity when the housing is opened e.g., during maintenance and service. In other respects, the protection classes of the housing must be observed.

#### 1.2.3.9 Design modifications

Sandvik assumes no liability or guarantee for any design modifications made to the vibrating machine system or additional components fitted to it that were not supplied by Sandvik. This especially applies to alterations which could affect the operating safety of the vibrating machine system.

#### 1.2.3.10 Replacing components

If parts must be replaced in the course of a repair, we recommend using original spare parts from Sandvik.

## 1.3 Contact us

1.3.1 Queries on new equipment, process development, technical matters, service exchange, exciter and vibrator motors, spare parts and maintenance should be directed to one of our branches directly.

1.3.2 Alternatively contact us by email at [srp.au@sandvik.com](mailto:srp.au@sandvik.com).



## 2 Screen components

### 2.1 Vibrating machine major components

- 2.1.1 The generic information contained within this section is provided to enable contextual identification of hazards that are listed throughout this Sandvik Vibrating machine safety manual (hereinafter also referred as this document).
- 2.1.2 The following figures are generic images added for general identification of major components of the vibrating machine:
- Screens pictured in Figure 2.2-1
  - Exciter driven feeder pictured in Figure 2.3-1
  - Suspended feeder pictured in Figure 2.4-1
  - Grizzly feeder pictured in Figure 2.5-1
- 2.1.3 This may not necessarily be indicative of the vibrating machine in operation on your site, and it is recommended to identify and review the IOM manual provided with your machine for specific component identification.
- 2.1.4 Vibrating machine components' descriptions may change depending on specific designs i.e.:
- Screens, single deck may replace top and bottom deck or dynamic exciter guard may replace static exciter guard or driven by exciter or vibrator motors.
  - Feeders, floor mounted or suspended feeder or driven by exciter or vibrator motors.
  - Grizzly, number and design of feeder stages or driven by exciter or vibrator motors.
- 2.1.4.1 Refer to your equipment IOM manual provided with your machine for specific component description.
- 2.1.5 If further clarification regarding component identification is required, please contact Sandvik.

## 2.2 Major screen components

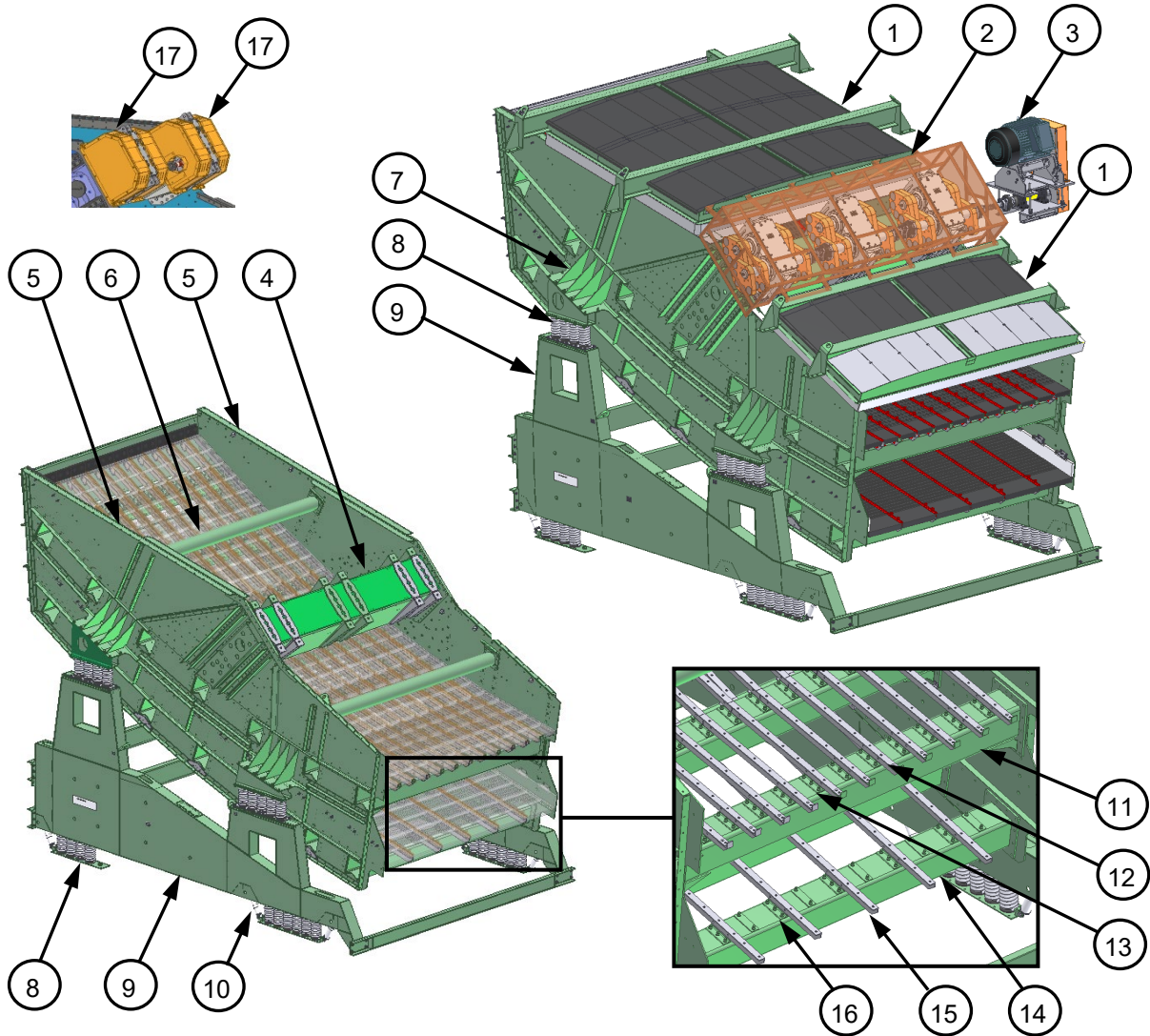

Figure 2.2-1 Main features of a double deck multi slope screen

Item	Description	Item	Description
1	Dust housings	10	Dampers
2	Static exciter guard	11	Top cross beams
3	Exciter & drive assembly	12	Top screen deck rails
4	Exciter beam	13	Top deck cleats
5	Side plate assemblies	14	Bottom cross beams
6	Pipe stiffeners	15	Bottom screen deck rails
7	Spring brackets	16	Bottom deck cleats
8	Springs	17	Dynamic exciter guard
9	Isolation frame		

**Uncontrolled copy when printed and/or not accessed from official Sandvik Rock Processing Australia Pty Ltd Intranet site.**

Title: Vibrating machine safety manual, Document Num: ENG-SDS-99

Approved By: D Teyhan, Approved Version: V4.0, Approval Date: 25/03/2024,

Filename: [https://sandvik.sharepoint.com/teams/p1ausportal/ims/eng/ENG-SDS-99\\_Vibrating Equipment Safety Manual.docx](https://sandvik.sharepoint.com/teams/p1ausportal/ims/eng/ENG-SDS-99_Vibrating Equipment Safety Manual.docx)

## 2.3 Major exciter driven feeder components

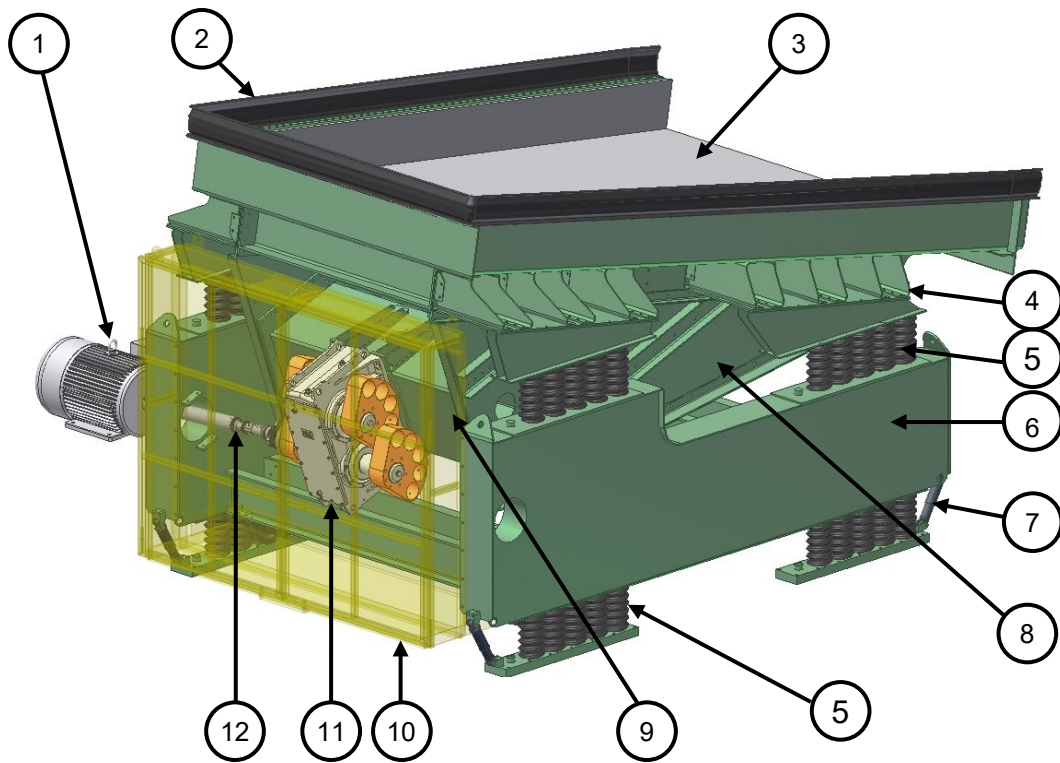

Figure 2.3-1 Main features of an exciter driven feeder

Item	Description	Item	Description
1	Drive motor	7	Dampers
2	Dust sealing	8	Feeder pan assembly
3	Feeder pan liners	9	Exciter beam
4	Spring brackets	10	Exciter guard
5	Springs	11	Exciter
6	Isolation frame	12	Exciter drive shaft

**Uncontrolled copy when printed and/or not accessed from official Sandvik Rock Processing Australia Pty Ltd Intranet site.**

Title: Vibrating machine safety manual, Document Num: ENG-SDS-99

Approved By: D Teyhan, Approved Version: V4.0, Approval Date: 25/03/2024,

Filename: [https://sandvik.sharepoint.com/teams/p1ausportal/ims/eng/ENG-SDS-99\\_Vibrating Equipment Safety Manual.docx](https://sandvik.sharepoint.com/teams/p1ausportal/ims/eng/ENG-SDS-99_Vibrating Equipment Safety Manual.docx)

## 2.4 Major suspended feeder components

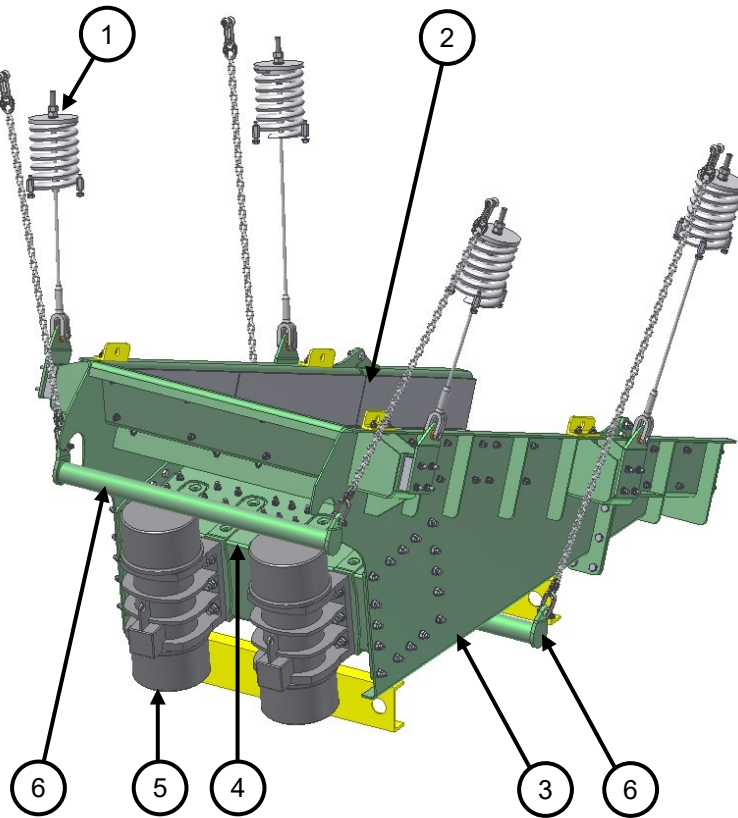

Figure 2.4-1 Main features of a suspended feeder

Item	Description
1	Support spring assembly
2	Feeder pan liners
3	Feeder pan assembly
4	Bolt in exciter beam
5	Vibrator motor
6	Safety bar assembly

**Uncontrolled copy when printed and/or not accessed from official Sandvik Rock Processing Australia Pty Ltd Intranet site.**

Title: Vibrating machine safety manual, Document Num: ENG-SDS-99

Approved By: D Teyhan, Approved Version: V4.0, Approval Date: 25/03/2024,

Filename: [https://sandvik.sharepoint.com/teams/p1ausportal/ims/eng/ENG-SDS-99\\_Vibrating Equipment Safety Manual.docx](https://sandvik.sharepoint.com/teams/p1ausportal/ims/eng/ENG-SDS-99_Vibrating Equipment Safety Manual.docx)

## 2.5 Major grizzly feeder components

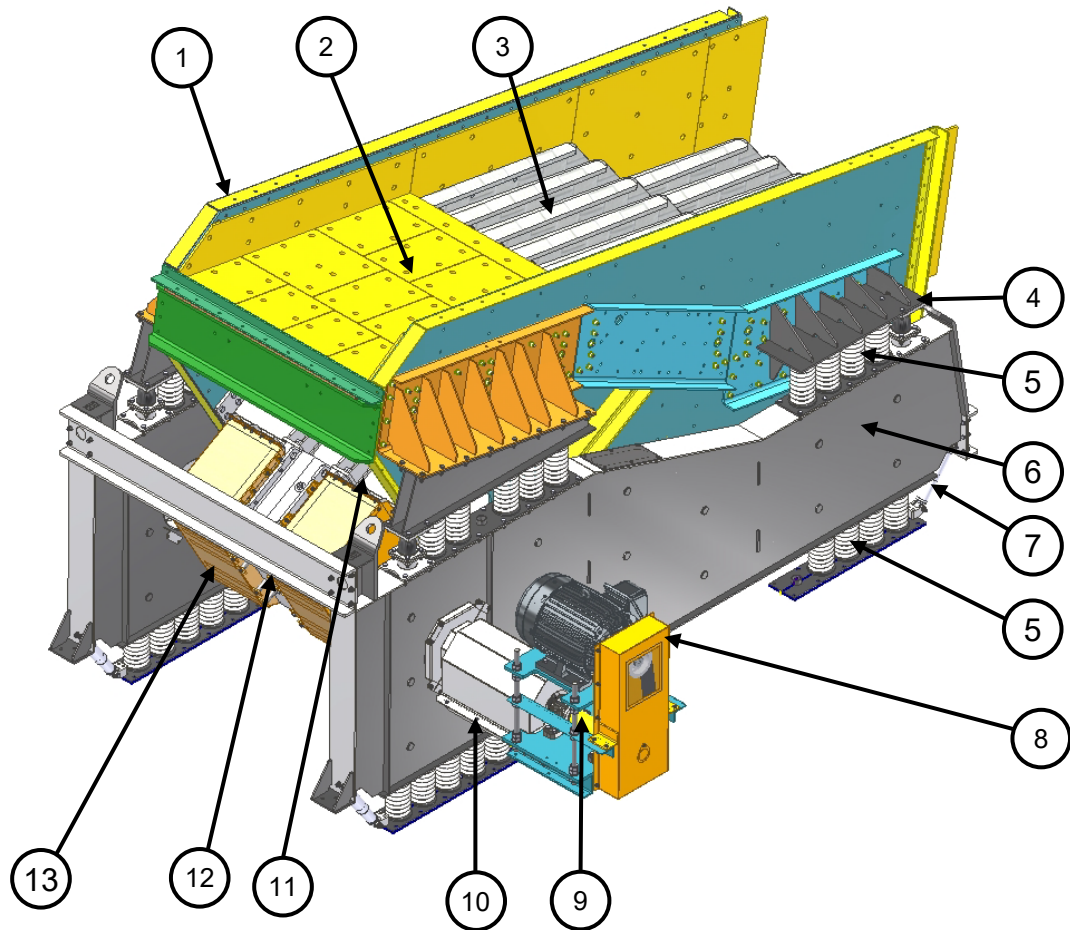

Figure 2.5-1: Main features of a grizzly

Item	Description	Item	Description
1	Grizzly body assembly	8	Drive assembly
2	Grizzly liners assembly	9	Lay shaft
3	Grizzly bars	10	Drive shaft guard
4	Spring brackets	11	Exciter beam
5	Springs	12	Exciter
6	Isolation frame	13	Exciter guard
7	Dampers		

**Uncontrolled copy when printed and/or not accessed from official Sandvik Rock Processing Australia Pty Ltd Intranet site.**

Title: Vibrating machine safety manual, Document Num: ENG-SDS-99

Approved By: D Teyhan, Approved Version: V4.0, Approval Date: 25/03/2024,

Filename: [https://sandvik.sharepoint.com/teams/p1ausportal/ims/eng/ENG-SDS-99\\_Vibrating Equipment Safety Manual.docx](https://sandvik.sharepoint.com/teams/p1ausportal/ims/eng/ENG-SDS-99_Vibrating Equipment Safety Manual.docx)

## 3 Signal words for safety warnings

### 3.1 Signal word severity

3.1.1 Potential dangers will always exist when working with technical devices. Dangers will arise if the machine:

- is incorrectly installed.
- is started up incorrectly.
- is operated by untrained personnel or
- is repaired by unqualified personnel.

3.1.2 The following signal words throughout this manual indicate inherent dangers that may arise when handling this machine:

3.1.3 Warning symbols associated with safety warnings are based on ISO 7010.



#### 1 DANGER

This signal word indicates a danger that can immediately cause the most severe injuries up to and including death.

Follow all instructions to prevent this from occurring.



#### WARNING

This signal word indicates a danger that can cause serious injuries up to and including death.

Follow all instructions to prevent this from occurring.



#### CAUTION

This signal word indicates a danger that can cause slight or medium injuries.

Follow all instructions to prevent this from occurring.

### 3.2 Signal Words for Application Notes

3.2.1 Signal words for information.



#### NOTICE

Signal word that contains important information

Follow all preventative instructions.



#### NOTICE

Signal words that are informative.

### 3.3 General electrical safety requirements

3.3.1 These safety rules must be followed in the order shown before work is begun on electrical systems. Once the work is finished, they are to be applied in reverse order. These general

**Uncontrolled copy when printed and/or not accessed from official Sandvik Rock Processing Australia Pty Ltd Intranet site.**

Title: Vibrating machine safety manual, Document Num: ENG-SDS-99

Approved By: D Teyhan, Approved Version: V4.0, Approval Date: 25/03/2024,

Filename: [https://sandvik.sharepoint.com/teams/p1ausportal/ims/eng/ENG-SDS-99\\_Vibrating Equipment Safety Manual.docx](https://sandvik.sharepoint.com/teams/p1ausportal/ims/eng/ENG-SDS-99_Vibrating Equipment Safety Manual.docx)

safety requirements need to be followed as a minimum; however, a risk assessment should be conducted with adequate isolation procedure put in isolation procedures to be reviewed and risk assessed on an installation specific basis prior to works commencing.



## DANGER

### Electric shock from live components.

There is a **danger to life** from an electric shock.

Take all possible precautions to ensure safety before work by qualified, competent, and authorised personnel has begun on live components. Observe, among other things, the following:

1. Fully disconnect the components from the electrical supply.
2. Secure them against inadvertent reconnection or energisation.
3. Ensure that the components have been disconnected from the electrical supply and verify they have been de-energized.
4. Cable voltages above 1 KV are required to be earthed before conducting activities to remove static charge.
5. Cover or shield adjacent, live components.



## NOTICE

### Electrical arc flash for electrical activities

It is the responsibility of the designer of the electrical supply for this equipment to undertake an arc fault study in accordance with the jurisdictional standards and legislative requirements. This is to ensure all the necessary measures are put in place to minimise the likelihood and consequences of an electrical arc fault occurrence.

## 3.4 Damaged / Defective electrical components



## DANGER

### Live damaged or defective components

There is a **danger to life** from an electric shock.

Always have qualified, competent, and authorised personnel and ensure that the components are neither damaged nor defective.

Qualified, competent, and authorised personnel must immediately replace or, if possible, repair damaged or defective electrical components.

## 3.5 System hazards



## DANGER

### Dangerously high hydraulic pressure.

**Severe physical injuries up to and including death can occur from sudden release of stored hydraulic pressure.**

Take all possible precautions to ensure safety from sudden release of stored hydraulic pressure, including but not limited to:

1. Ensuring that all sources of energy (stored or kinetic) which could cause sudden pressurization of the system are adequately isolated prior to commencing maintenance work.

**Uncontrolled copy when printed and/or not accessed from official Sandvik Rock Processing Australia Pty Ltd Intranet site.**

Title: Vibrating machine safety manual, Document Num: ENG-SDS-99

Approved By: D Teyhan, Approved Version: V4.0, Approval Date: 25/03/2024,

Filename: [https://sandvik.sharepoint.com/teams/p1ausportal/ims/eng/ENG-SDS-99\\_Vibrating Equipment Safety Manual.docx](https://sandvik.sharepoint.com/teams/p1ausportal/ims/eng/ENG-SDS-99_Vibrating Equipment Safety Manual.docx)

2. Confirming the system is depressurized prior to commencing maintenance work.
3. The energy of Greasing systems and Hydraulic system (if used) can be stored as hydraulic pressure.
4. Sudden release of stored hydraulic pressure has the potential to cause severe injury including death.
5. High pressure injection injuries from manual greasing system have the potential to cause severe injury including death.



## DANGER

### Electrical supply system danger

**There is a danger to life from an electric shock.**

Equipment might use sources of stored electrical energy whilst in operation.

Under no circumstances should any electrical equipment be opened without the appropriate isolation of the electrical system first being undertaken by qualified, competent, and authorised personnel.



## DANGER

### Design of electrical infrastructure and control systems may generate hazards including injury from electric shock and damage to equipment:

Sandvik provide equipment which often needs to be incorporated into an operators electrical and control network.

Failure to design electrical infrastructure in accordance with legislative requirements may result in contact between personnel and live conductors and equipment, or motor burn out and other equipment damage.

1. Operators and their third-party contractors should develop a robust 'Safety in design' procedure for infrastructure where they are the risk owners. Mandatory electrical design requirements in the area of jurisdiction need to be observed.
2. Sandvik recommend that new designs, plant upgrades, and modifications to old designs of electrical infrastructure involve a risk assessment and design peer review prior to implementation.
3. Installation shall be carried out by qualified and competent authorised personnel.
4. Commissioning checks should include verification of design conformance.



## CAUTION

### Air borne dust.

During operation, significant amounts of dust can be produced.

Depending on the application, a suitable dust control system can be implemented including, suppression, extraction or electrostatic.

This is to be completed in consultation with the original equipment manufacturer (OEM) of such systems and with process specialists who understand the screening process, feeding process and bulk material being handled.



## CAUTION

### Chemical Exposure.

This equipment may utilise lubricants, grease and hydraulic fluid in normal operations. Chemical exposure could cause skin irritation.

**Uncontrolled copy when printed and/or not accessed from official Sandvik Rock Processing Australia Pty Ltd Intranet site.**

Title: Vibrating machine safety manual, Document Num: ENG-SDS-99

Approved By: D Teyhan, Approved Version: V4.0, Approval Date: 25/03/2024,

Filename: [https://sandvik.sharepoint.com/teams/p1ausportal/ims/eng/ENG-SDS-99\\_Vibrating Equipment Safety Manual.docx](https://sandvik.sharepoint.com/teams/p1ausportal/ims/eng/ENG-SDS-99_Vibrating_Equipment_Safety_Manual.docx)





Personnel in contact with these products should consult relevant Material Safety Data Sheets (MSDS)



### CAUTION

#### Sharp edges.

Injury by exposure to worn and sharp edges

Wear appropriate gloves and Personal Protective Equipment (PPE) for protection for the task being performed.



### CAUTION

#### Noise.

Damage to hearing from working in noisy environments.

During operation, considerable noise may be generated from machinery operation and bulk material movement.

Personnel working in the vicinity of the vibrating machine should wear appropriate Personal Protective Equipment (PPE).



### CAUTION

#### Occupational vibration exposure.

Operators working around vibrating machines will be subject to structure borne vibration. ISO 2631.1 provides guidance on evaluation of human exposure to vibration

## 3.6 Moving equipment hazard



### DANGER

#### Danger to life from crushed body parts.

**Do not touch the vibrating machine and its moving parts during operation and only once returned to a safe state in accordance with site operational procedures prior to completing maintenance.**

Take all possible precautions to ensure safety before commencing work on or near vibrating machine. Observe among other things, the following:

1. Equipment moves during operation.
2. Restrain all moving components at lowest stored energy state.
3. Remove any supported loads.
4. Isolate all energy sources and secure against inadvertent restart.
5. Ensure zero pressure is indicated on all pressure gauges.
6. Stored energy is completely discharged from equipment.

**Uncontrolled copy when printed and/or not accessed from official Sandvik Rock Processing Australia Pty Ltd Intranet site.**

Title: Vibrating machine safety manual, Document Num: ENG-SDS-99

Approved By: D Teyhan, Approved Version: V4.0, Approval Date: 25/03/2024,

Filename: [https://sandvik.sharepoint.com/teams/p1ausportal/ims/eng/ENG-SDS-99\\_Vibrating Equipment Safety Manual.docx](https://sandvik.sharepoint.com/teams/p1ausportal/ims/eng/ENG-SDS-99_Vibrating Equipment Safety Manual.docx)



**DANGER**

**Danger to life from entanglement or crushed body parts.**  
**Injury or death from being caught in or struck by rotating components,** unguarded exciter, unguarded vibrator motor swing segments and drive train.  
 Correct installation and maintenance of guarding in accordance with Sandvik specifications is the recommended control to maintain high levels of performance, and safety:  
 Do not operate a machine without safeguards, substandard safeguards that may be unauthorized by the OEM, or damaged safeguards. Review the inspection and maintenance check list in the IOM supplied with the machine to identify the necessary checks to be completed to ensure that the equipment is maintained in a safe and reliable state and is in good working order.

### 3.7 Operational hazards

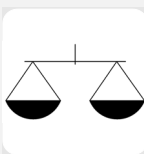

**NOTICE**

**Interlocking of CONiQ State Variables:**  
 Setting of inappropriate CONiQ State Variable alarm points can cause unwanted Vibrating machine shutdown or failure to shut the Vibrating machine down in a critical operating state. If setting interlocks based on CONiQ State Variables, consult with Sandvik for advice prior to implementation.

### 3.8 Stored mechanical energy hazards



**DANGER**

**Crush injury of hands and body parts**  
**Danger from unrestrained movement of rotating exciter and vibrator motor swing segments.**  
 Take all possible precautions to ensure the orientation that the swing segments are in the lowest potential state of stored energy prior to working on the exciters. -see Figure 3.8-1. Prior to removal of guards, ensure the swing segment are in the rest position.

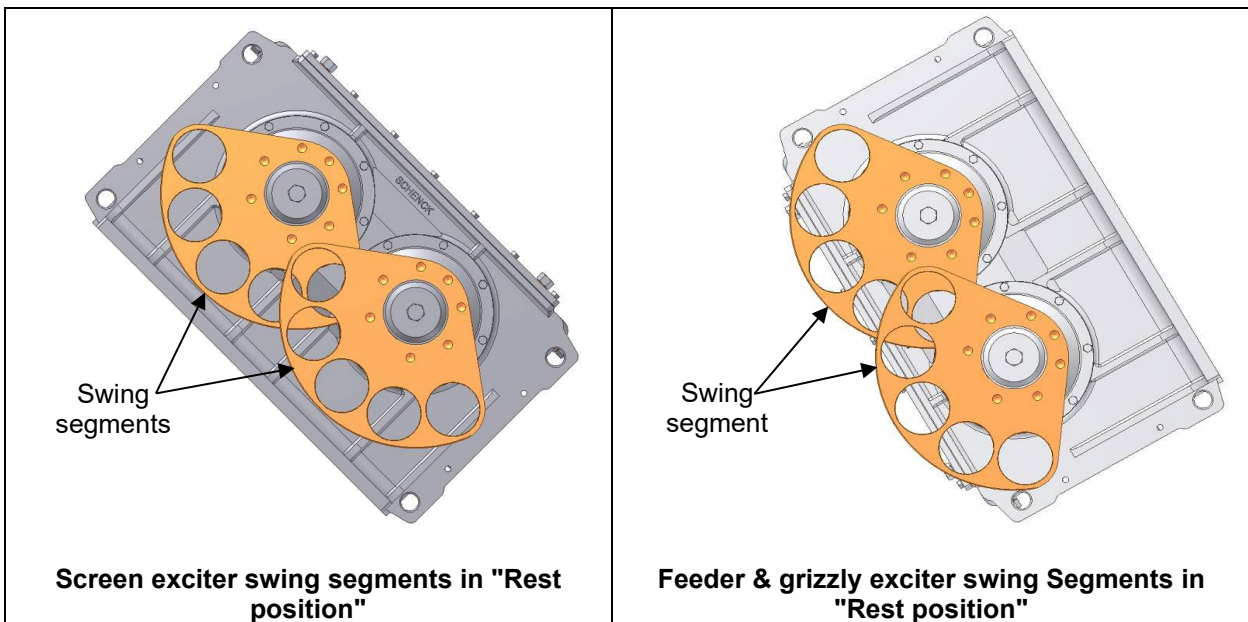

Figure 3.8-1- Exciter swing segment in “Rest position”

**Uncontrolled copy when printed and/or not accessed from official Sandvik Rock Processing Australia Pty Ltd Intranet site.**

## 4 General safety

### 4.1 Safety for installation, operation, and maintenance activities

4.1.1 The following precautions are applied to all installation, operation, and maintenance activities (referred to hereinafter as IOM activities).



#### **DANGER**

##### **Injury when working on operating equipment during installation, maintenance, repair, or cleaning.**

Personal injury from a fall from stationary or operating equipment, being struck by moving parts or being crushed by material.

Prior to working on equipment:

1. Isolate electrical supply to drive and material feed by qualified, competent, and authorised personnel, according to site safety procedures.
2. Ensure there is no trapped feed material in feed chutes that could fall during work.
3. Ensure equipment is at a complete stop before commencing any work.



#### **DANGER**

##### **Damage due to incorrect usage of equipment**

Rapid structural damage of the machine will occur.

Equipment will only function correctly with springs (isolation frame, and dampers if supplied) if correctly installed.

1. Do not operate the vibrating machine without the isolation frame dampers attached if supplied.
2. Do not alter the number of springs under either the vibrating machine or isolation frame without the prior written (e-mail sufficient) approval of Sandvik.
3. It is recommended that installation tasks are completed by personnel who are adequately trained and deemed competent for the task.



#### **DANGER**

##### **Danger of crushing from suspended loads**

Incorrect lifting of equipment can cause serious injury and even death.

Refer to Sandvik manuals supplied, lifting calculation documents (if supplied) and installation drawings for weights of machine components, lift positions and sling lengths.

1. Use correct lifting equipment and procedures suited to the load as defined by applicable standards, laws, and work practices.
2. Ensure lifting equipment is correctly rated to the load and lift conditions.
3. Only qualified personnel shall handle lifting of the machine.

All lifting equipment must be in a serviceable condition and comply with all applicable standards to ensure a safe lift.

***Uncontrolled copy when printed and/or not accessed from official Sandvik Rock Processing Australia Pty Ltd Intranet site.***

*Title: Vibrating machine safety manual, Document Num: ENG-SDS-99*

*Approved By: D Teyhan, Approved Version: V4.0, Approval Date: 25/03/2024,*

*Filename: [https://sandvik.sharepoint.com/teams/p1ausportal/ims/eng/ENG-SDS-99\\_Vibrating Equipment Safety Manual.docx](https://sandvik.sharepoint.com/teams/p1ausportal/ims/eng/ENG-SDS-99_Vibrating_Equipment_Safety_Manual.docx)*



## NOTICE

**Do not exceed lifting equipment ratings and vibrating machine mass with adherent bulk material.**

Vibrating machine lifting actions must be completed using the lifting devices and equipment as detailed on the lifting system drawing (if supplied).

To prevent an increase in lifting mass, all areas of the vibrating machine must be free of bulk material:

- 1 Remove bulk material adhering to the vibrating machine structure and deck aperture panels, feeder pans and grizzly bars.
- 2 Clean vibrating machine in accordance with site environmental plan and appropriate washing systems.



## NOTICE

**Electrical arc flash for electrical activities**

It is the responsibility of the designer of the electrical supply for this equipment to undertake an arc fault study in accordance with the jurisdictional standard and legislative requirements. This is to ensure all the necessary measures are put in place to minimize the likelihood and consequences of an electrical arc fault occurrence.



## NOTICE

**Do not lift equipment incorrectly or without suitable lifting equipment**

Damage to equipment.

To identify the vibrating machine lifting mass refer to the installation drawings (and lifting information if provided)

1. Adhering to the sling lengths will maintain the maximum "Sling Angles" as stated in the lifting calculation.
2. Refer to sling capacities and sling information as not to exceed maximum "Sling Angles" for the mass lifted.
3. Set the slings lengths to maintain the Vibrating machine and isolation frame at the intended installation angle.
4. Use lifting equalization rings in combination with slings during lift operations.



## DANGER

**Danger of crushing from suspended vibrating equipment**

**Some vibrating machines are suspended from above using cables, chains or similar.**

Do not stand under suspended vibrating equipment i.e., feeders.

4.1.2

Ensure all components used in the machines' suspension system i.e., springs, dampers, safety bars etc are installed and maintained correctly, are in good condition and do not rub or vibrate excessively during operation.



## DANGER

**Danger of crushing from equipment instability**

Personal injury from displaced equipment

Equipment can be pushed off supporting springs by sudden and uncontrolled introduction of feed:

1. Confirm feed chutes are clear of trapped material before start-up

***Uncontrolled copy when printed and/or not accessed from official Sandvik Rock Processing Australia Pty Ltd Intranet site.***

Title: Vibrating machine safety manual, Document Num: ENG-SDS-99

Approved By: D Teyhan, Approved Version: V4.0, Approval Date: 25/03/2024,

Filename: [https://sandvik.sharepoint.com/teams/p1ausportal/ims/eng/ENG-SDS-99\\_Vibrating Equipment Safety Manual.docx](https://sandvik.sharepoint.com/teams/p1ausportal/ims/eng/ENG-SDS-99_Vibrating_Equipment_Safety_Manual.docx)

## 5 Installation and commissioning safety

### 5.1 Installation, commissioning safety procedures

- 5.1.1 Site safety procedures should be followed at all times. The IOM procedures in the Sandvik manuals supplied with the vibrating machine are to be followed in conjunction with site procedures, not as a replacement of site procedures.
- 5.1.2 Refer to Section 1.1 - Occupational health and safety before commencing Installation and Commissioning of Sandvik equipment.



#### **DANGER**

##### **Serious injury from electric shock:**

Incorrect installation – resulting in contact with exposed conductors in the motor control centre, junction boxes, or other electrical enclosures.

1. Where possible, always apply electrical isolation to access points. Where isolation is not possible, all live conductors shall be covered by a barrier which requires a tool to remove.
2. Electrical enclosures should only be accessed by authorised and appropriately qualified personnel.
3. Where possible, use of components with IP2X protection of terminals is recommended. If IP2X protection of terminals cannot be achieved, suitable protection to be installed as per jurisdictional standards.



#### **DANGER**

##### **Serious injury from electric shock:**

Components may become live when in a malfunctioning state, particularly insulation breakdown.

1. Ensure earth leakage devices are applied and comply with the required regulatory standards in the area of jurisdiction.
2. Commissioning and operational checks of electrical systems shall include confirmation of earth leakage devices and earth fault loop impedance.
3. Carry out regular maintenance, inspection, and testing of earth leakage devices by qualified, competent, and authorised personnel.
4. Adequately rated short circuit protection devices shall be installed in accordance with the required regulatory standards in the area of jurisdiction.
5. Upstream short circuit protection devices may be installed to back up each protection device.



#### **DANGER**

##### **Serious injury from electric shock:**

The operating environment and electrical isolation (spring grommets, rubber springs etc) could lead to a static potential difference between equipment and the surrounding structure.

1. Earth bar and bonding cables to be run around and throughout all electrical enclosures. Electric motors shall be terminated with earth protection according to the manufacturer's recommendations. Earthing shall be applied in accordance with the required standards in the area of jurisdiction.
2. Carry out regular maintenance inspection of all earth bonding by qualified, competent, and authorised personnel.

***Uncontrolled copy when printed and/or not accessed from official Sandvik Rock Processing Australia Pty Ltd Intranet site.***

*Title: Vibrating machine safety manual, Document Num: ENG-SDS-99*

*Approved By: D Teyhan, Approved Version: V4.0, Approval Date: 25/03/2024,*

*Filename: [https://sandvik.sharepoint.com/teams/p1ausportal/ims/eng/ENG-SDS-99\\_Vibrating Equipment Safety Manual.docx](https://sandvik.sharepoint.com/teams/p1ausportal/ims/eng/ENG-SDS-99_Vibrating Equipment Safety Manual.docx)*

3. Ensure that the components have been de-energized.
4. Where risk of static charge build-up in the vibrating machine body is of concern due to electrical isolation, consider equipotential bonding to surrounding structural steelwork to dissipate the charge. If in doubt regarding fitment location and instructions, contact Sandvik for advice by contacting one of our branches directly.



## DANGER

### **Injury from burns and scalds:**

Thermal radiation, molten particles ejection, or chemical processes with short-circuits or electrical overloads.

1. All protective switching equipment to be contained in a suitable fit for purpose electrical enclosure.
2. Arc fault calculations shall be carried out, to determine the size of arc vents in the electrical enclosure where required.
3. Electrical isolation procedures to be in place before opening and working in the electrical enclosure.



## DANGER

### **Serious injury by electric shock or damage to equipment:**

Incorrect installation and wiring of electrical components may result in contact between personnel and live conductors or equipment.

1. Adhere to statutory protection requirements in the area of jurisdiction such as earthing, equipotential bonding, overcurrent and short circuit protection.
2. Installation to be carried out by qualified, competent, and authorised personnel.
3. Commissioning checks to include confirmation of wiring and equipment.



## NOTICE

### **Hazards due to installation of third-party equipment:**

Where operators or their third parties install substandard/ non-OEM electrical equipment (including condition monitoring systems and sensors), the design, risk management, statutory compliance with product standards, installation, and ongoing maintenance of operator installed electrical components remains the responsibility of the operator or their appointed third party.

1. Perform a risk assessment of any third-party installation prior to implementation.
2. Consult with your Sandvik representative for advice.



## NOTICE

### **Damage to equipment from conducting maintenance with power equipment:**

Where operators or shorting of power tools or arc welding on equipment may damage sensitive components.

1. Power equipment should be tested and tagged as fit for purpose.
2. Disconnect sensitive measurement equipment (such as ACS-s, CONiQ TSUs and linear differential transducers) prior to welding to any part of the structure.
3. Maintenance only to be carried out by qualified, competent, and authorised personnel.
4. Perform a site and task specific risk assessment prior to commencement of work.

***Uncontrolled copy when printed and/or not accessed from official Sandvik Rock Processing Australia Pty Ltd Intranet site.***

*Title: Vibrating machine safety manual, Document Num: ENG-SDS-99*

*Approved By: D Teyhan, Approved Version: V4.0, Approval Date: 25/03/2024,*

*Filename: [https://sandvik.sharepoint.com/teams/p1ausportal/ims/eng/ENG-SDS-99\\_Vibrating Equipment Safety Manual.docx](https://sandvik.sharepoint.com/teams/p1ausportal/ims/eng/ENG-SDS-99_Vibrating_Equipment_Safety_Manual.docx)*



## DANGER

### **Trolley garmotors attached with electric power cables:**

During maintenance movements, traversing movement of maintenance trolleys may cause track wheels to roll over power cables resulting in contact between personnel and live conductors, motor burnout, or other equipment damage.

1. Adhere to statutory protection requirements in the area of jurisdiction such as earthing, equipotential bonding, overcurrent and short circuit protection.
2. Installation to be carried out by qualified, competent, and authorised personnel.
3. Inspections to be carried out by qualified, competent, and authorised personnel.
4. Perform a site and task specific risk assessment prior to commencement of trolley movements. Use a spotter to ensure cables are out of the line of fire.

5.1.3 Before commencing vibrating machine operation, undertake checks in Section 7 - Operator connected and control system created hazards.

## 5.2 Transport beams safety



## DANGER

### **Crushing of fingers in transport beam mounting holes**

Injury or severing of fingers.

Do not place fingers in the transport beam mounting holes at any time during the removal process.

1. Use a drift to remove bolts and do not place any body parts beneath a suspended load.
2. Use appropriately rated temporary supports to arrest all stored potential energy and prevent work beneath suspended loads (refer to Figure 5.2-1- Appropriately rated supports and positioning instructions available from Sandvik upon request.
3. Your machine may be supplied on a transport frame. Refer to information supplied for handling instructions



**Figure 5.2-1: Example of rated supports for transport beam installation and removal**

***Uncontrolled copy when printed and/or not accessed from official Sandvik Rock Processing Australia Pty Ltd Intranet site.***

*Title: Vibrating machine safety manual, Document Num: ENG-SDS-99*

*Approved By: D Teyhan, Approved Version: V4.0, Approval Date: 25/03/2024,*

*Filename: [https://sandvik.sharepoint.com/teams/p1ausportal/ims/eng/ENG-SDS-99\\_Vibrating Equipment Safety Manual.docx](https://sandvik.sharepoint.com/teams/p1ausportal/ims/eng/ENG-SDS-99_Vibrating Equipment Safety Manual.docx)*



**DANGER**

**Compromised transport safety.**

Sandvik provides serialised transport beams matched to the equipment being transported. Use of unrated or un-serialised transport beams may compromise the transport safety, leading to damage to equipment, injury, or death.

1. Only use Sandvik supplied transport beams or frames specifically matched to the equipment being transported.
2. The transport beam or frame condition needs to be fit for purpose and installed per Sandvik instructions. Beams and frames should be discarded if cracked, bent, or corroded. If in doubt, contact Sandvik for a condition assessment.



**DANGER**

**Crushing of fingers in transport beam and bracket mounting holes**

Injury or severing of Fingers:

1. Do not place fingers in the transport beam and bracket mounting holes at any time during the installation process.
2. Use a tapered drift to align bolt holes and do not place any body parts beneath a suspended load.

**5.3 Exciter and drive train guarding**



**Figure 5.3-1: Exciter and drive train guarding**

5.3.1 Sandvik exciter and drivetrain guards are intended to prevent personnel coming into accidental contact with moving parts and to protect the exciter and drivetrain mechanisms

***Uncontrolled copy when printed and/or not accessed from official Sandvik Rock Processing Australia Pty Ltd Intranet site.***



from foreign objects which could damage the equipment, and themselves become projectiles after coming into contact with the equipment.

- 5.3.2 The guards are an integral part of the machine and must be maintained and free of defects in order to adequately provide the protection for which they have been designed.
- 5.3.3 The guards are not specifically designed to provide protection against ejected machine components which could occur in the event that the machine is operated in an unfit state, outside its rated working capacity, or as a result of improper maintenance.
- 5.3.4 Correct installation and maintenance in accordance with Sandvik specifications is the recommended control to maintain high levels of performance, and safety.
- 5.3.5 Operate machinery only when safeguards are properly installed and adjusted.
- 5.3.6 Do not operate a machine without safeguard, or safeguards that may be unauthorized by the OEM, or damaged.



### CAUTION

Mechanical exciter equipment is mainly used to drive vibratory vibrating machines with forces of up to 1000 kN per exciter. Exciters are designed to operate safely and reliably but require regular maintenance. When such an exciter is wrongly operated, not maintained to the OEM specified requirements or operated without a proper safeguard, there is a higher potential for hazardous situations to occur, such as:

1. Personnel can become entangled / burned / by unguarded exciter drive mechanisms and their moving parts
2. Personnel can be struck by loose objects. Unsecured or not properly fastened objects that may be triggered by long-term exposure such as incorrect operation, as well as corrosion etc.
3. Falling objects e.g., bolts or raw materials could cause injuries and other damages when they inadvertently come into contact with an unguarded exciter in operation.
4. Wearing Personal Protective Equipment (PPE) appropriate for the area of the plant in which the equipment is installed may reduce, but not exclude the risk posed by these projectiles.

## 5.4 Isolation frame and vibrating machine installation precautions

- 5.4.1 Observe the following precautions during installation of vibrating machine.



### DANGER

#### Crushing of fingers and hands in springs grommets and spring bases

Injury or severing of finger or hands.

Do not adjust spring positions by hand while equipment is being positioned.

1. Keep hands clear if springs require positioning.
2. Even the corrugations between coils on rubber encapsulated springs can cause pinching under sudden movement.
3. Be aware of potential energy risks during spring replacement procedures



### DANGER

#### Crushing of fingers in transport beam mounting holes

Injury or severing of fingers.

**Uncontrolled copy when printed and/or not accessed from official Sandvik Rock Processing Australia Pty Ltd Intranet site.**

Title: Vibrating machine safety manual, Document Num: ENG-SDS-99

Approved By: D Teyhan, Approved Version: V4.0, Approval Date: 25/03/2024,

Filename: [https://sandvik.sharepoint.com/teams/p1ausportal/ims/eng/ENG-SDS-99\\_Vibrating Equipment Safety Manual.docx](https://sandvik.sharepoint.com/teams/p1ausportal/ims/eng/ENG-SDS-99_Vibrating Equipment Safety Manual.docx)

Do not place fingers in the transport beam mounting holes at any time during the removal process.

Use a drift to remove bolts and do not place any body parts beneath a suspended load.



## **DANGER**

### **Failure to achieve installation configuration and tolerance on springs**

Vibrating machine and isolation frame springs rely on falling within the compression, level, and vertical alignment tolerances to maintain stability. Failure to observe spring tolerances may result in damage to, or ejection of springs during transient dynamic motion on start-up or shut down.

## 6 Operational safety

### 6.1 Operational safety precautions



#### **DANGER**

##### **Live damaged or defective components**

There is a danger to life from electrical shocks

Prior to start-up always have a qualified personnel confirm components are neither damaged nor defective:

1. The integrity of the electrical insulation of all electric motors must be confirmed.
2. Qualified personnel must immediately replace or if possible, repair damaged or defective electrical motors



#### **DANGER**

##### **Operating a damaged vibrating machine**

Rapid failure of the Vibrating machine and surrounding equipment may result if the vibrating machine is operated in a damaged or unfit state.



#### **DANGER**

##### **Injury from ejection of feed material from machine.**

Poorly controlled feed entry velocity can result in ejection of particles and impact injuries. Material ejected from equipment may cause serious injury and even death.

During the plant design process:

1. Feed chute (by others) shall cause the feed material to land on blank region of the screen deck or feeder pan and be directed towards discharge end of the Vibrating machine.
2. Minimise drop height onto the screen feed end impact panels through positioning of feed equipment within 0.5 m vertical height of the feed end impact panels. Where this is not possible, feed chutes with velocity control ledges should be implemented
3. For coarse dry screening, mean flow velocity should be limited to 3 m/s with a maximum resultant particle velocity of 5 m/s.
4. Flow control curtains or chains, and hungry boards can be implemented to prevent spillage.
5. For Pan Feeder and Grizzly applications, uncontrolled drop height and feed entry velocity is often part of the operating conditions of the equipment. Ensure suitably designed Feeder enclosures, Hungry Boards, and Side Skirts prevent risk of material ejection during infeed conditions.

During operation always stand clear of feed entry locations where a risk of falling particles or engulfment may exist.



#### **DANGER**

##### **Serious injury from electric shock:**

Components may become live when in a malfunctioning state, particularly insulation breakdown.

1. Ensure earth leakage devices are applied and comply with the required standards in the area of jurisdiction.
2. Commissioning and operational checks of electrical systems shall include confirmation of earth leakage devices and earth fault loop impedance.

***Uncontrolled copy when printed and/or not accessed from official Sandvik Rock Processing Australia Pty Ltd Intranet site.***

*Title: Vibrating machine safety manual, Document Num: ENG-SDS-99*

*Approved By: D Teyhan, Approved Version: V4.0, Approval Date: 25/03/2024,*

*Filename: [https://sandvik.sharepoint.com/teams/p1ausportal/ims/eng/ENG-SDS-99\\_Vibrating Equipment Safety Manual.docx](https://sandvik.sharepoint.com/teams/p1ausportal/ims/eng/ENG-SDS-99_Vibrating_Equipment_Safety_Manual.docx)*

3. Carry out regular maintenance, inspection, and testing of earth leakage devices by a by qualified, competent, and authorised personnel.
4. Adequately rated short circuit protection devices shall be installed in accordance with the required standards in the area of jurisdiction.
5. Upstream short circuit protection devices may be installed to back up each protection device.

- 6.1.1 Always maintain the static clearances specified in the installation drawing from the vibrating machine to other objects.
- 6.1.2 Always ensure proper maintenance is carried out on the vibrating machine in accordance with the Sandvik maintenance manual supplied.
- 6.1.3 Always follow site procedures for vibrating machine start-up and shutdown in addition to the procedures specified in this manual. This will ensure the safety of both equipment and personnel.
- 6.1.4 If in doubt as to whether a vibrating machine is in sound operating condition, to mitigate potential risks, we recommend treating the machine as if it is not in safe working condition until clarified. To clarify, review the Sandvik maintenance manual, Part 3, and if further assistance is required, contact Sandvik.



## DANGER

### **Changes to vibrator or drive motor power, vibrator or exciter operating speed, plug weight settings or counterweight setting**

Rapid structural damage of the machine if it is not operated as designed.

Do not change the drive motor, motor power, connection method, VSD drive parameters (if applicable), Exciter operating speed or plug weight settings of the vibrating machine without the prior written approval of Sandvik Engineers.

The motor power connection method should not be modified without prior approval of Sandvik Engineers. e.g., addition of soft starts, variable speed drives etc.

## 6.2 Vibrating machine and exciter start-up procedures



## DANGER

### **Restarting the vibrating machine before all motion has ceased**

Catastrophic failure of the vibrating machine and surrounding equipment may result.

Excessive stroke can occur if vibrating machine is restarted while slowing down:

1. The equipment must be at a complete stop before restarting.
2. The vibrating machine moves through frequencies of increased stroke during shutdown. The period of time spent at these frequencies is normally short but can be prolonged if start-up recommences at these speed

- 6.2.1 Start-up must be from rest. Following a shut-down event, allow the vibrating machine motion to cease completely before re-starting. Restarting during vibrating machine run-down may cause excessive stroke to occur during passage through the spring resonance speed, causing damage to the vibrating machine. Run down will take at least 2 minutes.



## CAUTION

**Vibrating machine may generate high levels of infrasound**

***Uncontrolled copy when printed and/or not accessed from official Sandvik Rock Processing Australia Pty Ltd Intranet site.***

*Title: Vibrating machine safety manual, Document Num: ENG-SDS-99*

*Approved By: D Teyhan, Approved Version: V4.0, Approval Date: 25/03/2024,*

*Filename: [https://sandvik.sharepoint.com/teams/p1ausportal/ims/eng/ENG-SDS-99\\_Vibrating Equipment Safety Manual.docx](https://sandvik.sharepoint.com/teams/p1ausportal/ims/eng/ENG-SDS-99_Vibrating_Equipment_Safety_Manual.docx)*

Infrasound is low frequency airborne vibration below the human hearing threshold. Investigations into the health effects of infrasound are constantly evolving. Site personnel should be aware that high levels of infrasound exist in and around mineral processing plants and take measures to reduce exposure wherever possible.

## 7 Operator connected and control system created hazards

### 7.1 Prestart checks

7.1.1 Prior to starting the vibrating machine, ensure that:

- Nobody is working on the machine or on any downstream equipment that could be affected by material discharged from the vibrating machine.
- The machine is in a fit state to operate before beginning a task, any previous fault conditions have been resolved, any maintenance work has been fully completed, the deck systems, feeder pan liners, or grizzly bars fully installed and secured.
- The Screen or Grizzly is clear of material or foreign objects, retained material loads in excess of normal operating material loadings must be cleared prior to operation. Screens that have been 'bogged' must not be started until the material has been cleared.
- Pan Feeders may be re-started with a surcharge load of material. Starting torque requirements for Pan Feeders is generally lower than that of a screen, and a properly designed feed hopper will limit the loads transferred to a feeder during start-up conditions.
- The machine's exciters or vibrator motors have come to a complete stop – vibrating machine should not be restarted whilst the exciters or vibrator motors are still rotating.
- Note: when using surge or material storage bin arrangements with a Pan Feeder, initial fill conditions can result in high Feeder Loading and over-compression of coil springs. It is recommended that shut off gates are used for initial fill of bins, or that the material storage bins over Pan Feeders are only partially filled before the Feeder is run for a short period of time. Operating the Feeder for a short time allows arched, self-supporting stress fields to develop within the bulk material, reducing the loading on the Feeder Pan.

### 7.2 Pre-stop checks

7.2.1 Prior to stopping the machine ensure that:

- The exciters and vibrator motors have reached operational speed, vibrating machine should not be stopped whilst the exciters or vibrator motors are still accelerating up to speed.
- Equipment feeding material onto a Screen or Grizzly has been stopped and is no longer discharging material onto the vibrating machine.
- Avoid stopping Screens and Grizzlies if material is still on the deck(s).
- If a screen or Grizzly has been stopped with material still being fed from upstream equipment (crash stop):
  - the screen or grizzly must be visually inspected to ensure that its deck has not been loaded with material exceeding nominal design bed depths prior to restarting.

### 7.3 Checks prior to starting feed onto the vibrating machine

7.3.1 Prior to introducing feed onto the vibrating machine from upstream equipment, ensure that:

- Where equipped and required as part of the screening process, the water spray system is operating.
- Vibrating Screens or Grizzlies are operating and running at their design run speed – feed should never be fed onto a stationary vibrating machine, a vibrating machine that is accelerating up to speed or a vibrating machine that this operating at a speed other than its design speed.

***Uncontrolled copy when printed and/or not accessed from official Sandvik Rock Processing Australia Pty Ltd Intranet site.***

- Feeders in an initial bin fill situation have either isolation gates closed to prevent excess head load and impacting, or a residual amount of material left in the hopper to prevent direct impact on the feeder pan.
- The downstream equipment (conveyors, chutes, pumps etc.) is operating and ready to accept the discharge material and nobody is present on the downstream equipment.
- The machine is in a fit state to receive feed. Material should not be fed onto a vibrating machine that has unresolved faults or abnormal motion.

## **7.4 Checks after commencement of feed onto the vibrating machine and periodic checks.**

7.4.1 After material feed onto the vibrating machine has commenced and periodically during operation, check that:

- The material is passing freely over the vibrating machine (not being impeded on the screen decks, feeder pan, grizzly bars, or other areas of the vibrating machine, not adhering to the vibrating machine and building up).
- The material is not rebounding abnormally on the vibrating machine and is being constrained within the vibrating machine or hungry boards/side skirts where used (excessive conveyor speeds and/or high drop heights can result in rebounding of material).
- The discharge material is flowing freely through discharge equipment (not backing up towards the vibrating machine).
- The feed is within the design specifications. The maximum lump size, feed rate, moisture and adhesion are within the design limits for the vibrating machine.
- Where fitted and required as part of the screening process the spray water is operating and being directed correctly onto the process material. Avoid spray water being directed at the vibrating machine structural components.

## 8 Maintenance safety

### 8.1 Maintenance safety procedures

- 8.1.1 Completing maintenance on vibrating machinery is critical in order to maintain safe and efficient operation. The maintenance requirements, processes and intervals are defined within the IOM manual provided with your specific machine. This section contains general recommendations which must be observed during the maintenance of vibrating machines, as well as some of the more critical maintenance activities that must be observed to ensure safe operation of the equipment.
- 8.1.2 Site safety procedures and Section 1.1 - Occupational health and [safety procedures](#) should be followed at all times. The IOM procedures in the Sandvik manuals supplied with the vibrating machine are to be followed in conjunction with site procedures, not as a replacement of site procedures.



#### **DANGER**

##### **Serious injury from electric shock:**

Approaching electrically live equipment – particularly motor terminal blocks of screens where motors are mounted on self-tensioning drive bases. Motor may move unexpectedly due to drive load changes.

1. Electrical isolation procedures to be in place for working on or near electrically live equipment.
2. Site/Task specific risk assessment to be conducted before commencing work.
3. Only appropriately qualified and competent personnel should ever work on live equipment.



#### **DANGER**

##### **Serious Injury by electric shock or damage to equipment:**

Failure or malfunctioning of electrical components including motor failure, ingress of water, contactor failure, or failure of protection to electrical equipment may result in contact between personnel and live conductors or equipment.

1. Adhere to statutory protection requirements in the area of jurisdiction such as earthing, equipotential bonding, overcurrent and short circuit protection.
2. Inspection to be carried out by qualified, competent, and authorised personnel.
3. Carry out regular maintenance inspections and testing of earth leakage devices.



#### **DANGER**

##### **Serious Injury by electric shock:**

Conducting maintenance on vibrating machines – outboard electric motors, vibrating motors, gearbox cooling system, tractive drive motors, ACS-s CONiQ condition monitoring equipment, linear differential transducers, or other electrical equipment.

1. Maintenance to be carried out by qualified, competent, and authorised personnel.
2. Site/Task specific risk assessment to be conducted and site procedures followed before commencing work.
3. Use fit for purpose PPE.
4. Carry out regular maintenance inspection and testing of earth leakage devices.

***Uncontrolled copy when printed and/or not accessed from official Sandvik Rock Processing Australia Pty Ltd Intranet site.***

Title: Vibrating machine safety manual, Document Num: ENG-SDS-99

Approved By: D Teyhan, Approved Version: V4.0, Approval Date: 25/03/2024,

Filename: [https://sandvik.sharepoint.com/teams/p1ausportal/ims/eng/ENG-SDS-99\\_Vibrating Equipment Safety Manual.docx](https://sandvik.sharepoint.com/teams/p1ausportal/ims/eng/ENG-SDS-99_Vibrating_Equipment_Safety_Manual.docx)



- 8.1.3 Work on the vibrating machine should be conducted only after the vibrating machine drive or vibrator motor and material feed systems have been isolated according to site safety procedures.
- 8.1.4 Welding Sandvik vibrating machines can void equipment warranty and could cause a fire. Do not attempt any welding repairs without prior consultation and written (e-mail sufficient) consent from Sandvik Engineers.



## DANGER

**Sandvik acknowledge that in some circumstances weld repairs to vibrating equipment are unavoidable. Where Sandvik has authorised weld repairs, observe the following:**

Failure to correctly earth welding equipment may result in equipment damage or electric shock. Some component connections may electrically isolate parts of the machine. Other components such as exciter bearings and drive shafts are highly sensitive to electric current.

1. Ensure that welding equipment is earthed as close to the weld repair as possible and on the component being repaired. If in doubt, check the impedance before energising welding equipment.
2. Never earth on, or weld to an exciter housing or drive shaft. If exciter or drive shaft components are damaged, they must be replaced and never weld repaired.



## DANGER

**Do not weld any parts of vibrating machines**

Rapid and catastrophic failure of the equipment or chance of fire.

Vibrating machines are subject to dynamic stress fatigue which will greatly increase as a result of any welding process.

1. Do not attempt any welding procedures without prior consultation and consent of Sandvik Engineers.
2. Seek written (e-mail sufficient) consent of any welding procedures from Sandvik Engineers  
⇒ Welding Sandvik Vibrating machine can void warranty and cause a fire

- 8.1.5 There are potentially flammable components on the vibrating machine. Appropriate controls to be implemented by owners / maintainers during maintenance procedures to mitigate risk of combustion.



## WARNING

**Flammable materials are used in the construction of Sandvik equipment.**

Carrying out “Hot Work” on equipment can cause fire in the vibrating machine and surrounding equipment.

Some parts of the vibrating machine are flammable. These include but not limited to screening deck components, wear resistant coatings and rubber dust seals.

1. Ensure all safety precautions relating to flammable materials are observed when working on or around Sandvik equipment

- 8.1.6 Before commencing maintenance on any drive components i.e., pullies, belts, drive, and Intermediate shafts, ensure exciter swing segments are in the rest position as shown in Figure 3.8-1- Exciter swing segment in “Rest position”

- 8.1.7 Before commencing vibrating machine operation, undertake checks in Section 5 - Installation and commissioning safety, Section 6 - Operational safety and Section 7- Operator connected and control system created hazards.

## Danger

**Uncontrolled copy when printed and/or not accessed from official Sandvik Rock Processing Australia Pty Ltd Intranet site.**

Title: Vibrating machine safety manual, Document Num: ENG-SDS-99

Approved By: D Teyhan, Approved Version: V4.0, Approval Date: 25/03/2024,

Filename: [https://sandvik.sharepoint.com/teams/p1ausportal/ims/eng/ENG-SDS-99\\_Vibrating Equipment Safety Manual.docx](https://sandvik.sharepoint.com/teams/p1ausportal/ims/eng/ENG-SDS-99_Vibrating Equipment Safety Manual.docx)

**Ensure dampers are fitted to isolation frames**

Excessive isolation frame movement and potential spring instability  
Prior to starting equipment:

1. Check dampers are fitted and in good working condition.

**NOTICE****A minor problem, if ignored may rapidly develop into a major structural failure**

Catastrophic failure of the equipment  
Because the entire machine is vibrating:

It is crucial that components be in sound condition.

Minor problems will cause neighbouring components to be more highly stressed making failure considerably more likely.

## 8.2 Spring removal and replacement safety procedures

- 8.2.1 Replace broken Springs immediately. Springs normally have a long life, unless mistreated or material build-up in the coils is allowed to occur. The failure of one spring may indicate that the entire set of springs is reaching the end of its service life. It is recommended that if one spring fails, all springs at that point of support should be replaced.
- 8.2.2 Only the Sandvik specified spring type and configuration to be used otherwise potential risk of spring ejection or dislodgement.

**DANGER****Injury when working on operating equipment with incorrect support.**

Personal injury from stationary or operating equipment, struck by moving parts or being crushed by material if the equipment is not properly supported by spring configurations specified by Sandvik.

Prior to working on or operating equipment:

1. Confirm the equipment is supported by Sandvik specified spring configuration only.
2. Ensure there are no missing or damaged springs.

- 8.2.3 Replace all missing or damaged springs with the procedure described in the Section 8.2- Spring removal and replacement safety procedures

**NOTICE****Only use Sandvik specified spring configuration**

Damage to equipment by operating equipment outside design parameters, instability due to missing springs and incorrect supporting spring configurations  
For equipment spring configurations, please refer to the installation drawings:

1. Use of incorrect spring configuration could result the potential risk of spring ejection.
2. Use of incorrect spring configuration could result the potential risk of spring dislodgment.

- 8.2.4 If hydraulic jacks are used, only lift at the jacking locations indicated on the installation drawing. If a crane is used, the lifting lugs of the equipment can be used. Controls need to be introduced to prevent working beneath a suspended load.
- 8.2.5 Contact Sandvik Engineers if unsure of lifting or jacking locations.

**DANGER**

**Uncontrolled copy when printed and/or not accessed from official Sandvik Rock Processing Australia Pty Ltd Intranet site.**

**Crushing of fingers and hands if using spring compression clamps**

Injury or severing of finger or hands. Sudden release of potential energy and ejection of parts  
Do not use spring compression clamps for spring installation and removal.

1. Use appropriate lifting or jacking methods for spring removal.
2. Avoid stored potential energy.

**DANGER****Uncontrolled movement of load if synchronised lifting process is not used during jacking**

Injury or severing of finger or hands.

Ensure that vibrating machine is lifted evenly on both sides with lifting control or a sequential process. Failure to maintain levels within 20 mm from side to side during the lifting operation may result in jacking cylinder instability.

**DANGER****Danger of Crushing from Hanging Feeders**

Incorrect lifting of equipment when replacing springs can cause serious injury and even death.

- Refer to manuals supplied, install drawings (and lifting calculation documents if provided) for weights of machine components, lift positions and sling lengths.

1. Use correct lifting equipment and procedures suited to the load as defined by applicable standards, laws, and work practices.
2. Ensure lifting equipment is correctly rated to the load and lift conditions.
3. Use lifting slings attached to the lifting lugs provided to support the hanging feeder when replacing springs.
4. The hanging feeder should be fully supported by the slings to allow safe removal of springs.
5. Ensure the hanging feeder support springs are not under compression when replacing.
6. Only suitably qualified personnel shall handle lifting of the machine.  
⇒ All lifting equipment must be in a serviceable condition and comply with all applicable standards to ensure a safe lift.

**DANGER****Crushing of fingers and hands in springs grommets and spring bases**

Injury or severing of finger or hands.

Do not adjust spring positions by hand while equipment is being positioned.

3. Keep hands clear if springs require positioning.
4. Even the corrugations between coils on rubber encapsulated springs can cause pinching under sudden movement.
5. Be aware of potential energy risks during spring replacement procedures

**CAUTION****Sharp Edges**

Exposure to worn and sharp edges

Wear appropriate gloves and Personal Protective Equipment (PPE) for protection.

- 8.2.6 Ensure that fingers are clear of the coils at all times during spring loading and unloading, even with Enduro rubber encapsulated springs.

### 8.3 Screen deck panel maintenance

- 8.3.1 Screen decks are fitted with screening media (panels) which are made from various materials, but most typically, steel, rubber, or polyurethane. During operation these panels are subject to abrasive wear which reduces their cross-sectional area, and thereby reduces their load carrying capacity. Panels must be replaced periodically when they are no longer fit for purpose. This is usually a function of their aperture size wearing to a point where they are no longer able to achieve the target separation performance requirements of the screening process.
- 8.3.2 Panel maintenance processes currently requires maintenance personnel to access the deck of the screen in order to manually inspect and replace them. In these situations, the condition of the panels may not be known until the maintainer is on the deck and being supported by the panels and deck rails.



#### CAUTION

Before any personnel access the deck of the screen it is strongly recommended that a thorough risk assessment be carried out as there is potential for unknown hazards to have developed to the screening surface over the course of the screen's previous duty cycle. These may include, but are not limited to:

1. Worn or broken panels,
2. Damp, slippery, and uneven surfaces,
3. Exposed panel grids or worn wedge wires resulting in sharp edges,
4. Open holes,
5. Trip hazards,
6. Buildup of unprocessed material.

Additionally, some installation conditions may require a confined space and or working at heights permit to be completed and the necessary control measures implemented prior to entry.

### 8.4 Feeder pan liner maintenance

- 8.4.1.1 Feeder pan liners are manufactured from wear resistant material. During operation, these liners are subject to abrasive wear which reduces their cross-sectional area. On extreme occasion, the liner and supporting feeder pan may be worn though, have loose or missing hardware, or have sharp edges, presenting hazards for maintenance personnel. Many feeders are designed with replaceable pan liners which should be replaced when they are no longer fit for purpose.
- 8.4.1.2 Pan liner maintenance currently requires maintenance personnel to access the feeder pan in order to manually inspect and replace them. In these situations, the condition of the liners may not be known until the maintainer is on the feeder and being supported by the liners.

***Uncontrolled copy when printed and/or not accessed from official Sandvik Rock Processing Australia Pty Ltd Intranet site.***

*Title: Vibrating machine safety manual, Document Num: ENG-SDS-99*

*Approved By: D Teyhan, Approved Version: V4.0, Approval Date: 25/03/2024,*

*Filename: [https://sandvik.sharepoint.com/teams/p1ausportal/ims/eng/ENG-SDS-99\\_Vibrating Equipment Safety Manual.docx](https://sandvik.sharepoint.com/teams/p1ausportal/ims/eng/ENG-SDS-99_Vibrating Equipment Safety Manual.docx)*



## **DANGER**

### **Danger of crushing from suspended loads**

Incorrect lifting of equipment can cause serious injury and even death.

- Refer to manuals supplied and install drawings for weights of machine components, lift positions and sling lengths if required.
- 1. Use correct lifting equipment and procedures suited to the load as defined by applicable standards, laws and work practices.
- 2. Ensure lifting equipment is correctly rated to the load and lift conditions.
- 3. Only suitably qualified personnel shall handle lifting of the machine.
  - ⇒ All lifting equipment must be in a serviceable condition and comply with all applicable standards to ensure a safe lift.

- 8.4.1.3 The mass of the liners will present additional hazards during maintenance removal and replacement operations.



## **WARNING**

### **Injury when removing worn Feeder Pan Liners**

Cuts to hands and body parts from sharp edges on worn liners.

- 8.4.1.4 Gaps between replaced liners may be filled with epoxy.



## **WARNING**

### **Exposure to respiratory and skin irritating chemicals in a confined space**

Exposure to epoxy chemicals in confined areas may cause skin, eye irritations or breathing difficulties.

- Prior to handling epoxy chemicals in confined areas:

1. Wear protective clothing such as disposable overalls, rubber gloves and eye protection.
2. Use a respirator when using epoxy in confined spaces
3. Adhere to all relevant confined space work procedures.

## **8.5 Grizzly bar, Impact pan, Side Liner and Deflector maintenance.**

- 8.5.1.1 Grizzly bars, Impact Pan Liners, Side Liners, and Deflectors are manufactured from wear resistant material. During operation, these items are subject to impact and abrasive wear which may damage the components or reduce their cross-sectional area. On extreme occasions, the grizzly bars, Liners, Impact Pans, and Deflectors may be worn though, presenting hazards for maintenance personnel. Many Grizzly wear parts are removable, and designed to be replaced when they are no longer fit for purpose.

- 8.5.1.2 Grizzly maintenance currently requires maintenance personnel to access the Grizzly Bars, and Impact pan in order to manually inspect and replace them. In these situations, the condition of the bars may not be known until the maintainer is being supported by them.

- 8.5.2 Worn Grizzly Bars, Impact Pan, Side Liners, and Deflectors may present sharp edges during maintenance operations.

***Uncontrolled copy when printed and/or not accessed from official Sandvik Rock Processing Australia Pty Ltd Intranet site.***

*Title: Vibrating machine safety manual, Document Num: ENG-SDS-99*

*Approved By: D Teyhan, Approved Version: V4.0, Approval Date: 25/03/2024,*

*Filename: [https://sandvik.sharepoint.com/teams/p1ausportal/ims/eng/ENG-SDS-99\\_Vibrating Equipment Safety Manual.docx](https://sandvik.sharepoint.com/teams/p1ausportal/ims/eng/ENG-SDS-99_Vibrating Equipment Safety Manual.docx)*



## DANGER

### Danger of crushing from suspended loads

Incorrect lifting of equipment can cause serious injury and even death.

- Refer to manuals supplied and install drawings for weights of machine components, lift positions and sling lengths if required.

1. Use correct lifting equipment and procedures suited to the load as defined by applicable standards, laws, and work practices.
2. Ensure lifting equipment is correctly rated to the load and lift conditions.
3. Only suitably qualified personnel shall handle lifting of the machine.  
⇒ All lifting equipment must be in a serviceable condition and comply with all applicable standards to ensure a safe lift.

- 8.5.2.1 The mass of the Grizzly Bar, Impact Pan Liners, Side Liners, and Deflectors will present additional hazards during maintenance removal and replacement operations.



## WARNING

### Injury when removing worn Grizzly Pan Liners

Cuts to hands and body parts from sharp edges on worn Liners.

- 8.5.2.2 Gaps between replaced liners may be filled with epoxy.



## WARNING

### Exposure to respiratory and skin irritating chemicals in a confined space

Exposed to epoxy chemicals in confined areas may cause skin, eye irritations or breathing difficulties.

- Prior to handling epoxy chemicals in confined areas:

1. Wear protective clothing such as disposable overalls, rubber gloves and eye protection.
2. Use a respirator when using epoxy in confined spaces
3. Adhere to all relevant confined space work procedures.

## 8.6 Exciter and drivetrain maintenance

- 8.6.1 The exciters and drive train of vibrating machines consist of an assembly of mechanical components which operate at high speed and contain significant levels of kinetic energy. It is critical to ongoing safe and reliable operation of the machine that regular inspections and maintenance are carried out in accordance with the IOM provided. This section outlines the general requirements for the inspection of exciters and drivetrains and is supplementary guidance to that contained within the IOM.



## DANGER

### Crush injury of hands and body parts

Danger from unrestrained movement of rotating exciter swing segments.

Take all possible precautions to ensure the orientation that the swing segments are in the lowest potential state of stored energy prior to working on the exciters. -see Figure 8.6-1. Prior to removal of guards, ensure the swing segment are in the rest position.

***Uncontrolled copy when printed and/or not accessed from official Sandvik Rock Processing Australia Pty Ltd Intranet site.***

Title: Vibrating machine safety manual, Document Num: ENG-SDS-99

Approved By: D Teyhan, Approved Version: V4.0, Approval Date: 25/03/2024,

Filename: [https://sandvik.sharepoint.com/teams/p1ausportal/ims/eng/ENG-SDS-99\\_Vibrating Equipment Safety Manual.docx](https://sandvik.sharepoint.com/teams/p1ausportal/ims/eng/ENG-SDS-99_Vibrating_Equipment_Safety_Manual.docx)

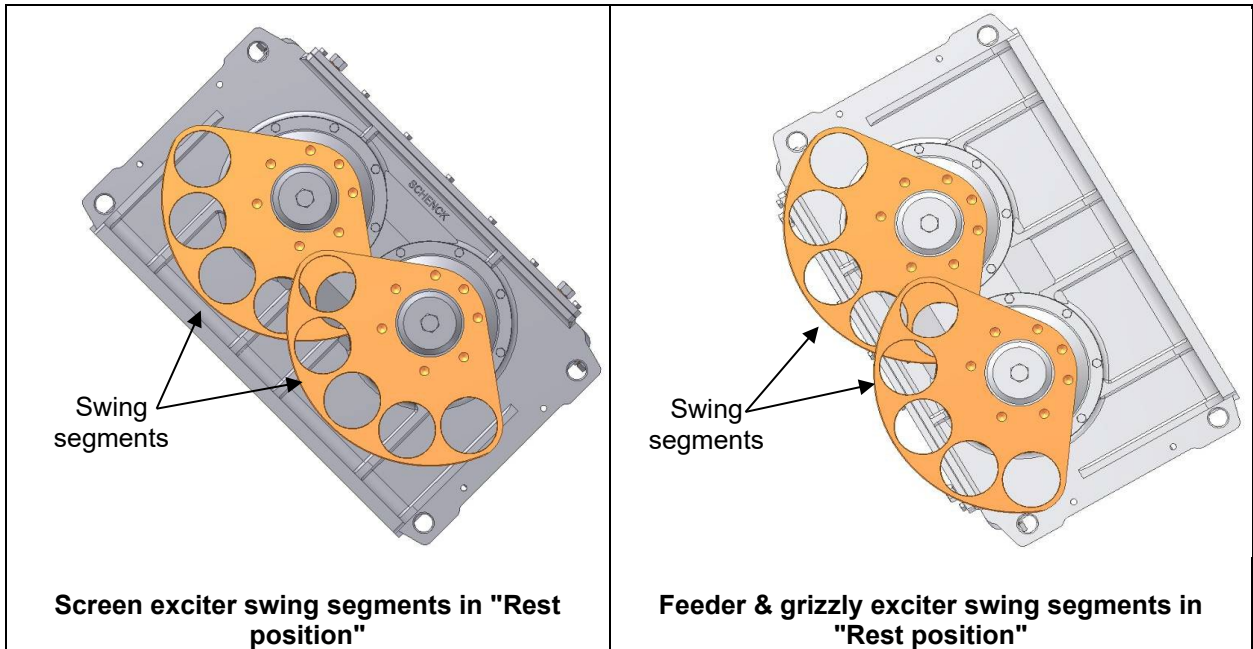

**Figure 8.6-1: Exciter swing segment in "Rest position"**

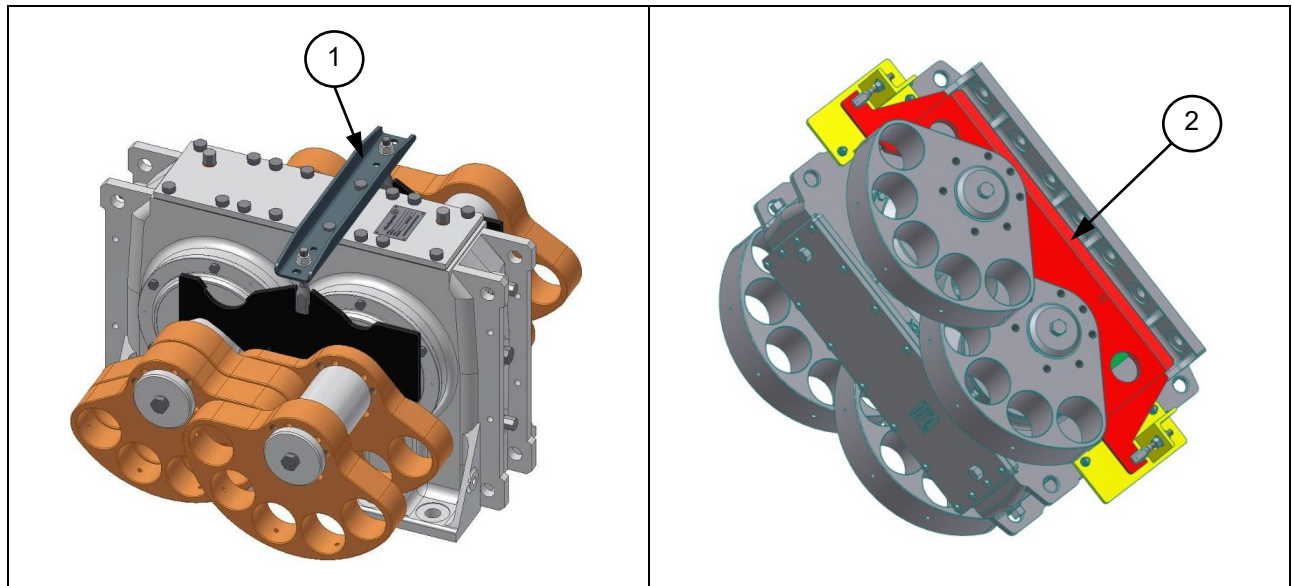

Screen exciter transport clamp

Feeder and grizzly exciter swing segment clamp

**Figure 8.6-2: Swing segments secured with transport clamps**

Item	Description
1	Screen exciter transport clamp
2	Feeder and grizzly exciter swing segment clamp

8.6.2 For exciter installation, removal, and for some maintenance operations, it is necessary to rotate the swing segments by lifting. Prior to conducting work under elevated swing segments, ensure that they are fully secured against unexpected movement due to gravity. Refer to the IOM. Supplied with the equipment for guidance.

**Uncontrolled copy when printed and/or not accessed from official Sandvik Rock Processing Australia Pty Ltd Intranet site.**

- 8.6.3 Correct installation of plug weights, and roll pins are critical to maintain the safe operation of the vibrating machine.
- 8.6.4 Regularly inspect rotating components for signs of damage, cracks, and corrosion, and immediately replace using genuine OEM parts only.
- 8.6.5 Exciters, vibrator motors and layshafts contain rolling element bearings which have finite service lives due to wear and fatigue, the lives vary from machine to machine depending upon exciter force, speed and operating duty. Frequent and correct maintenance and correct operation will extend these service lives, however replacement of exciters, vibrator motors and layshafts should be expected during the operating life of a vibrating machine and is not a defect.
- 8.6.6 Regularly check the condition of exciters, vibrator motors, and layshaft bearings using vibration analysis and temperature measurement. Where bearings have developed faults, they should be removed from service promptly. Exciters and vibrator motors require specialist equipment and skills to replace bearings and should be returned to Sandvik for refurbishment. Due to high operational loads, exciter bearing damage will progress rapidly.



## DANGER

### **Risk of catastrophic failure of exciters and vibrator motors when operated in a compromised condition**

Exciters and vibrator motors operate at high speed and with high levels of kinetic energy which may be released if operated with damaged bearings or gears. Abnormal impact vibrations caused by damaged bearings or gears may cause loosening and detachment of exciter or vibrator motor components.

1. Ensure that exciters and vibrator motors are regularly monitored using an ACS-s CONiQ system or similar vibration analysis programme.
2. If bearing damage is detected ensure that the exciter or vibrator motor is removed from service promptly and returned to Sandvik for refurbishment.
3. Never operate an exciter or vibrator motor that is audibly noisy from bearing or gear damage or is overheating or has any signs of damage.
4. Do not attempt to cool down an overheating exciter or vibrator motor using water or any other method – remove it from service.

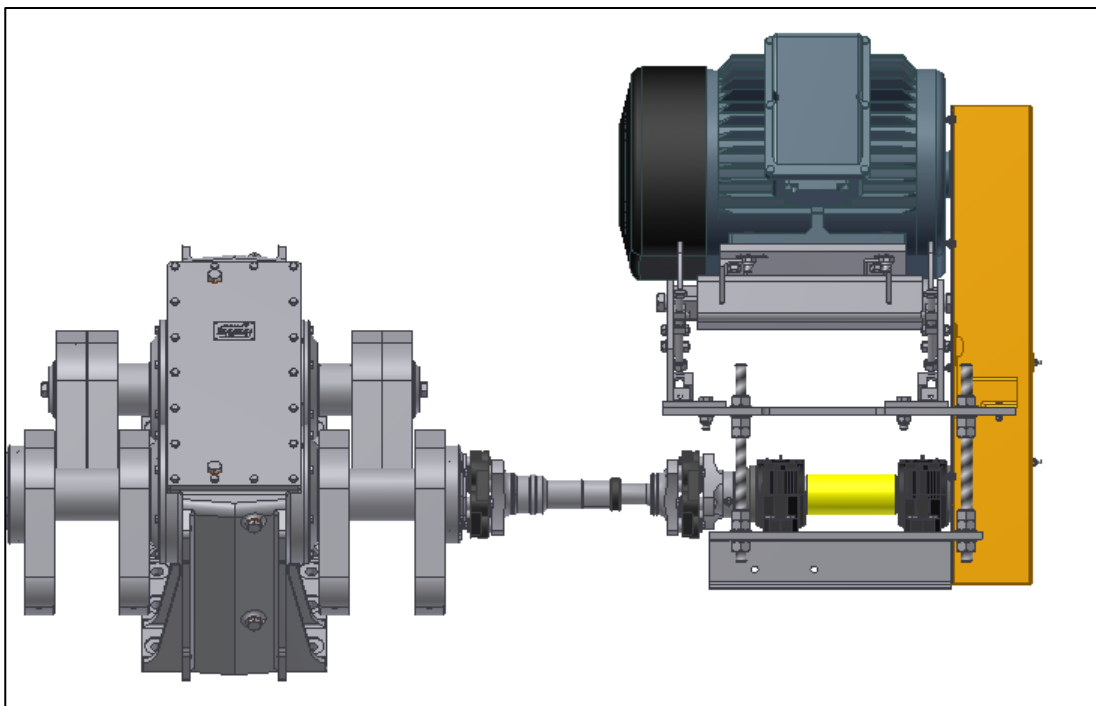

***Uncontrolled copy when printed and/or not accessed from official Sandvik Rock Processing Australia Pty Ltd Intranet site.***

*Title: Vibrating machine safety manual, Document Num: ENG-SDS-99*

*Approved By: D Teyhan, Approved Version: V4.0, Approval Date: 25/03/2024,*

*Filename: [https://sandvik.sharepoint.com/teams/p1ausportal/ims/eng/ENG-SDS-99\\_Vibrating Equipment Safety Manual.docx](https://sandvik.sharepoint.com/teams/p1ausportal/ims/eng/ENG-SDS-99_Vibrating Equipment Safety Manual.docx)*



Figure 8.6-3 Generic exciter drive shaft and coupling assembly

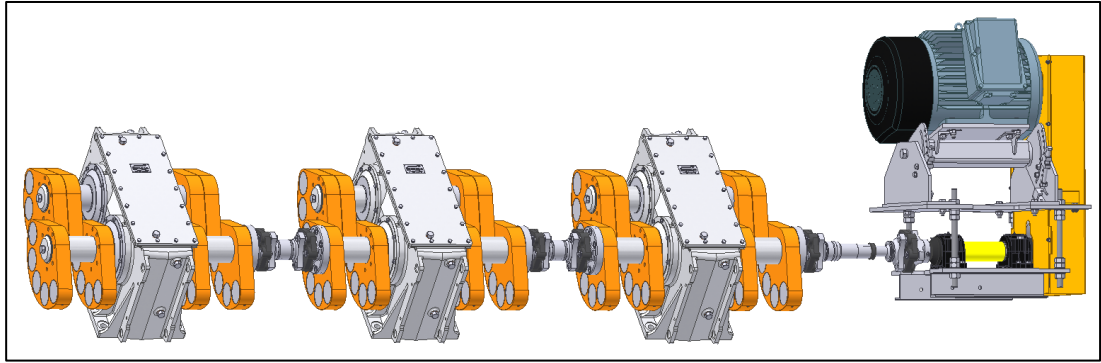

Figure 8.6-4 Example exciter & drive train assembly

- 8.6.7 Drive train assemblies consist of multiple mechanical components and fasteners that operate under cyclic loads with high rotational kinetic energy.
- 8.6.8 Regular inspection of components in accordance with the intervals specified within the IOM provided with your equipment is critical to ensure the continued safe operation of the vibrating machine.



## NOTICE

**A minor problem, if ignored may rapidly develop into a major structural failure**

This will cause catastrophic failure of the equipment.

Because the entire machine is vibrating, it is crucial that components be in sound condition.

Minor problems will cause neighbouring components to be more highly stressed making failure considerably more likely.

## 8.7 Exciter, drive train and vibrator motor safety critical inspections

8.7.1 The following checklists are to be copied and used in routine inspections to form a record of the screen condition at that time. We recommend that they are used as an aid to condition monitoring and maintenance planning.

**Table 8.7-1 On-line Check List**

<b>On-line check list</b> Maximum inspection period 200 hours.	
<b>Exciter</b>	
1.	Check exciter while running for any indication of oil leakage from the exciter. <b>DO NOT REMOVE GUARDS!</b> NB: Labyrinths will shed grease when exciter is new. DO NOT regrease labyrinths.
2.	Check exciter while running for possible noise.
3.	Using ACS-s CONiQ, check exciter for excessive operating temperature. NB: 1 hour running required to reach operating temperature which will vary with ambient temp.
4.	Check the exciter operating in a dry environment i.e., free from process water and slurry exposure.
5.	Check mechanism for possible excessive operating temperature with oil temperature immersion probe. NB:1 hour running required to reach operating temperature
<b>Drive and Drive Shafts</b>	
1.	Check motor mountings for any indication of looseness.
2.	Check motor bearings for possible noise or excessive operating temperature.
3.	Check guards are in good condition, free of corrosion and cracks – replace any corroded or cracked guard components including fasteners immediately upon identification
4.	Check lay shaft bearings for noise or excessive operating temperature (30°C above ambient is OK).
5.	Check Vee belts visually for possible breakage or loss of tension.
6.	Check for process water or slurry leaking outside the screen i.e., side plate, springs or crossbeam covers.
<b>Vibrator motor</b>	
1.	Check for any indication of oil/grease leakage
2.	Check for loose fixings.
3.	Check while running for abnormal noise.
4.	Check after running for at least ½ hour for excessive vibrator motor operating temperature, using a non-contacting thermometer.

**Uncontrolled copy when printed and/or not accessed from official Sandvik Rock Processing Australia Pty Ltd Intranet site.**

Title: Vibrating machine safety manual, Document Num: ENG-SDS-99

Approved By: D Teyhan, Approved Version: V4.0, Approval Date: 25/03/2024,

Filename: [https://sandvik.sharepoint.com/teams/p1ausportal/ims/eng/ENG-SDS-99\\_Vibrating Equipment Safety Manual.docx](https://sandvik.sharepoint.com/teams/p1ausportal/ims/eng/ENG-SDS-99_Vibrating Equipment Safety Manual.docx)

**Table 8.7-2: Off-Line Check List**

<b>Off-Line Check List</b> <b>Maximum Inspection Period 1000 Hours.</b>
<b>Exciter</b>
Check oil level in exciters using dipstick. Remove dipstick after, replace seal washer & plug. oil level should be checked prior to start-up of screen, or in case of continuous operation, screen should be stopped a sufficient length of time to allow all oil to drain to bottom of mechanism housing.
Change oil after 1000 hours of service and have oil sample* analysed
Check for any indication of oil leakage from the exciters. NB labyrinths will shed grease when exciter is new. Do NOT regrease labyrinths.
Check oil in housing for indication of contamination. If present, drain and refill with correct amount new oil. Monitor oil. Obtain an oil analysis* to determine source of contamination.
Check for possible loose mechanisms, such as bolts. Immediately report and rectify to restore to the requirements specified on the assembly drawing of the machine.
Check plug weights and roll pins for correct installation (seated and secured in accordance with IOM and installation drawings)
<b>Drive and drive shafts</b>
Check motor mountings for any indication of looseness.
Check drive shafts and couplings for signs of corrosion and cracking and replace with genuine OEM components if cracks or corrosion are identified.
Check drive & intermediate shaft rubber couplings for possible cracking every 6 months (maximum)
Check drive shaft spline for possible free play & replenish grease every 6 months (maximum)
Check guards are in good condition & free from cracks, with all fasteners present free of corrosion and not loose.
Referring to the IOM manual, check lay shaft bearing lubrication – replenish with grease every 1000 hours or per lubrication schedule table, whichever is sooner
<b>Vibrator motor</b>
Check for any indication of oil/grease leakage
Check for loose fixings.
Check after running for at least ½ hour for excessive vibrator motor operating temperature, using a non-contacting thermometer.

\*Recommended oil sampling and analysis:

- Oil sampling should be carried out by qualified and accredited personnel, with minimum ISO 18436-4 (MLA) accreditation recommended.

#### 8.7.2 Oil sampling notes:

- It is essential to ensure that the sampling method is consistent and representative of the operating conditions; sampling must be conducted before any particulate contamination has settled – within 1 hour of the exciter being shut down from a fully warmed up operation.
- The results should be compared to analysis of fresh unused oil, it should not be assumed that new oil is uncontaminated.
- As a minimum, oil analysis should include oil viscosity, water content using the “Karl Fischer Titration” method, oxidation, particle count code to ISO 4406 and elemental analysis (ppm of metals, contaminants, and additives). Other analyses such as PQ index and acid number may assist in diagnosis.

***Uncontrolled copy when printed and/or not accessed from official Sandvik Rock Processing Australia Pty Ltd Intranet site.***

Title: Vibrating machine safety manual, Document Num: ENG-SDS-99

Approved By: D Teyhan, Approved Version: V4.0, Approval Date: 25/03/2024,

Filename: [https://sandvik.sharepoint.com/teams/p1ausportal/ims/eng/ENG-SDS-99\\_Vibrating Equipment Safety Manual.docx](https://sandvik.sharepoint.com/teams/p1ausportal/ims/eng/ENG-SDS-99_Vibrating Equipment Safety Manual.docx)

- 8.7.3 With exciters, oil analysis is suitable for the identification of issues related to oil condition, oil cleanliness and for diagnosis purposes (e.g., identification of origins of contamination), it is not a substitute for vibration based condition monitoring of exciters which can provide more timely and definitive indications of exciter condition.

## 8.8 Lubrication safety

- 8.8.1 Observe the following precautions during lubrication operations.



### **DANGER**

#### **Exciter mechanisms are supplied without oil**

Catastrophic exciter damage on start-up will result if the exciter is not filled with oil.

Prior to start-up:

1. Refer to your equipment IOM manual for oil type, viscosity, and exciter oil level information
2. Ensure equipment is at a complete stop and appropriately isolated before commencing any work.

Sandvik exciters utilise oil splash lubrication with internal oil flingers, felt oil seals and an external labyrinth that is initially grease packed. New exciters often shed grease from the labyrinth seals. This is not a fault and the labyrinths do not require regreasing.

3. If exciters are operated without oil, even for a short duration, permanent damage to the bearings will occur that can only be rectified by bearing replacement – remove the exciter from service and return to Sandvik for evaluation and refurbishment.



### **DANGER**

#### **Only sufficiently trained and qualified personnel are to work on exciters**

Rapid structural damage of the exciter and machine may occur if it is not maintained correctly.

Contact Sandvik for exciter maintenance.

## 9 Decommissioning, dismantling, transport, recycle and disposal

### 9.1 Decommissioning

- 9.1.1 The decommissioning, dismantling, transport, recycle, and disposal are centred on the end of the equipment useful life.
- 9.1.2 Risk assessments in accordance with the latest best practices should be conducted at the time of decommissioning, dismantling, transport, recycle, and disposal to account for any hazards identified post design and construction.
- 9.1.3 When undertaking decommissioning, the equipment must be made safe to take out of service and cease operation.
- 9.1.4 Decommission equipment by:
- a) Observing all safety instructions noted in this procedure.
  - b) Stop feed material to the equipment.
  - c) Isolate and disconnect all power sources ensuring that the remaining infrastructure is in a safe state. This activity shall be completed and verified by a competent and suitably authorised person.
  - d) Secure equipment against stored energy and moving equipment hazards.
  - e) Secure equipment and surrounding plant from inadvertent restart.
  - f) Remove exciter guarding and immediately install exciter swing segments clamps to prevent injury when working exciters and drive components.
  - g) With exciter swing segments secure, drain exciter oil and dispose in accordance with site requirements and local environment laws.

### 9.2 Dismantling

- 9.2.1 Assess machine and components for hazards before dismantling. Refer to Section 8.3 if working at heights.
- 9.2.2 Use the following procedure if equipment requires dismantling.
1. Inspect all lifting provisions for signs of damage and make good where required.
  2. Ensure swing segment clamps are installed on the exciters before removing drive guarding and components.
  3. Guard against crushing of fingers when removing belts, pulleys, taper locks if supplied.
  4. If required, assess deck panels and supporting structure for hazards before removal.
  5. If required, remove exciters, vibrator motors, electric motors or other major components while observing all safe lifting requirements.
  6. Assess condition of the components for reuse, refurbishment, or disposal.

### 9.3 Transport

- 9.3.1 If the equipment is required to be transported, install transport beam in accordance with Section 5.2.

***Uncontrolled copy when printed and/or not accessed from official Sandvik Rock Processing Australia Pty Ltd Intranet site.***

- 9.3.2 Use suitable lifting equipment to transport the equipment while observing all safe lifting requirement.
- 9.3.3 Refer to transport documentation to ensure minimum required transport trailer width and permissible lashing locations are observed.

## **9.4 Recycling**

- 9.4.1 Check all dismantled components for hazards when assessing suitability for reuse, refurbishment, recycling, or disposal.
- 9.4.2 Any components identified for reuse and refurbishments should be stored as detailed in [ENG-SMS-930 Extended Storage](#) procedure.
- 9.4.3 Any recyclable or valuable materials should be identified during this process.
- 9.4.4 Recycle components in accordance with site requirements and local environment laws.

## **9.5 Disposal**

- 9.5.1 At the time of disposal, equipment may contain materials that could be considered environmentally hazardous. Prior to disposal of equipment, seek the Safety Data Sheets for the equipment and consumables used therein which are supplied as part of the Manufacturer's Data Report (MDR) at time of purchase. In the event that these are not locatable, please contact Sandvik for support.