

Magnetic drum separators for QA range screens

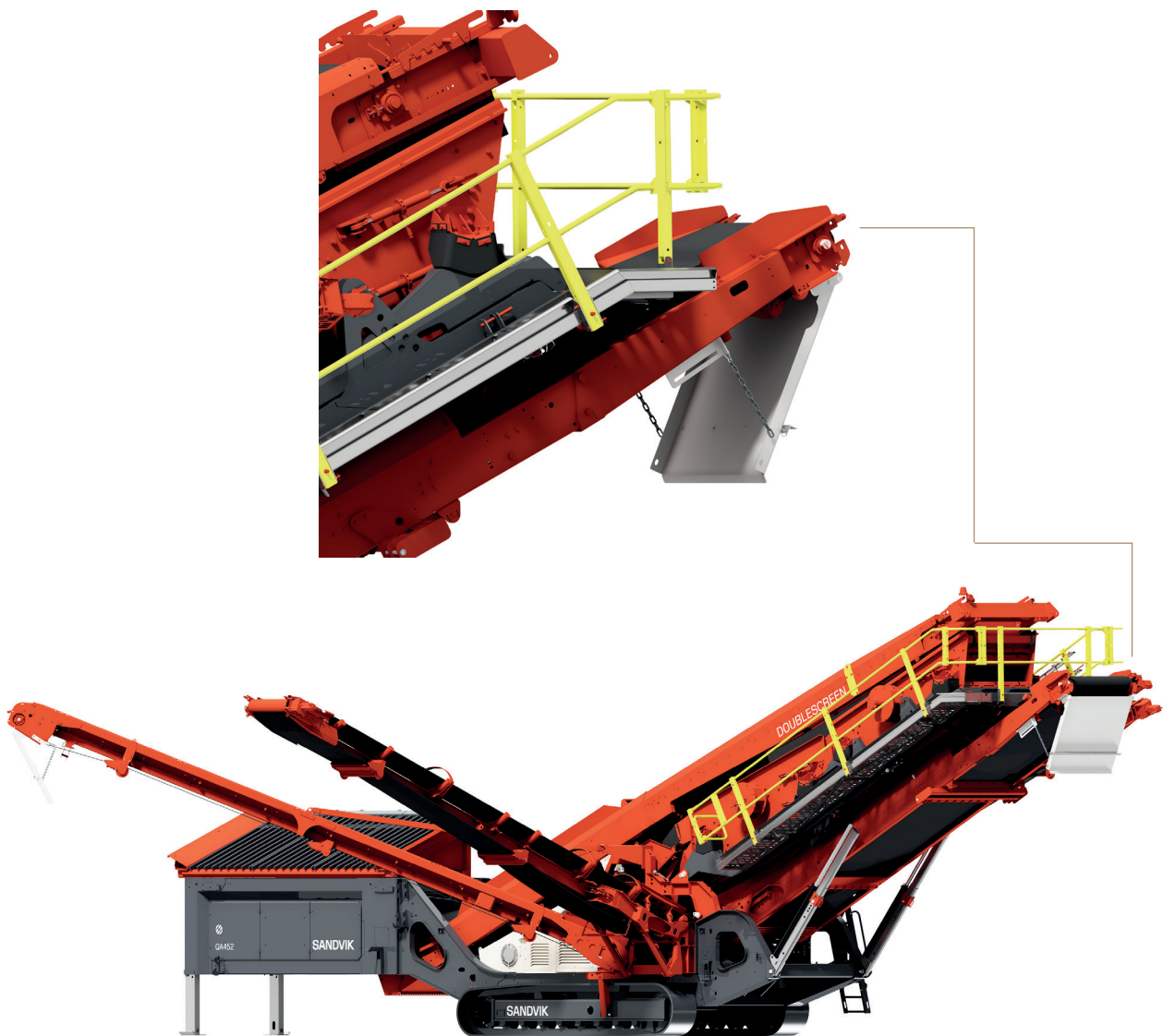

Maximum extraction and cleaner product

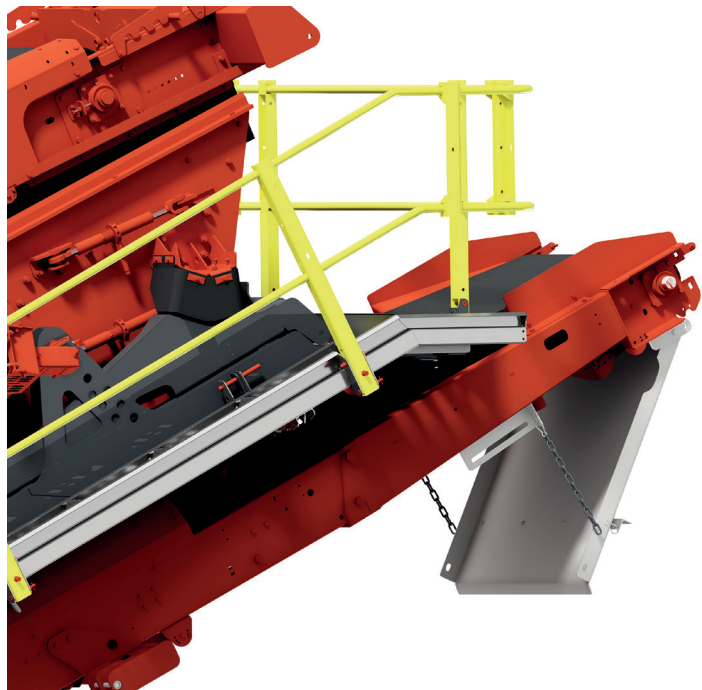

Sandvik magnetic drum separators are now available to purchase and retrofit to QA442 / QA452 and QA441 / QA451 mobile screens, enabling ferrous material separation on fines product conveyors and the oversize product conveyor on the QA451 / QA452.

These are of benefit in the following applications:

- Clean a contaminated feed material before further processing and or protect a downstream piece of equipment eg. oversize material being fed back in “closed circuit” with a cone crusher in a quarry / aggregate processing application.
- Remove ferrous metal from a contaminated waste stream, eg. construction and demolition waste, recycled aggregates / wood / mulch / biomass.

Unwanted ferrous metal particles can be collected and turned into a valuable sellable product for metal recycling.

The head drums have a large magnetic surface area and are very close to the product ensuring even the smallest particles are collected and efficiently removed.

Features

- Efficient and clean extraction of ferrous materials
- Removal of metals for recycling
- Minimal maintenance
- Straightforward to install

Each magnetic drum package typically consists of:

- 1 off magnetic head drum
- 1 off aluminium discharge chute
- 1 off discharge chute
- 4 off mounting brackets
- 2 off mounting chains
- All mounting hardware
- Fitting instructions

The magnetic drums are available for the following QA range screener models, as well as preceding models.

Model	Part Numbers	
	Fines	Oversize
QA441 / QA442	SD009504	
QA451 / QA452	SD009504	SE004708